

9LD@898`J=K
 77; 5`HF5M6CL`GMGH9A
 %&+a a `D=H7 <

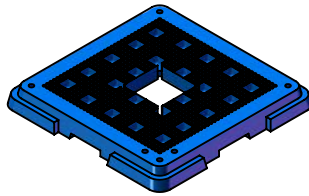

8K; '\$' & '+*
 6 @ 9`75FF=9F
 %\$`r`%\$`%&-

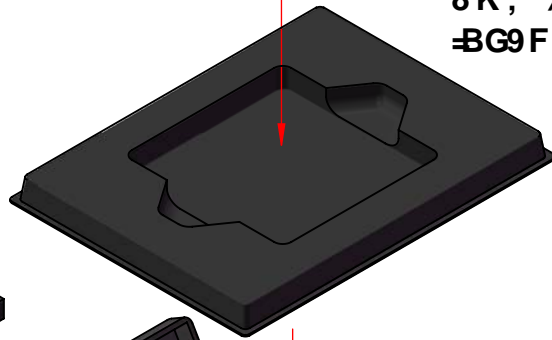

8K; '%\$%\$
 =BG9FH`%\$(`r`%\$`)



5 GG9A6 @8

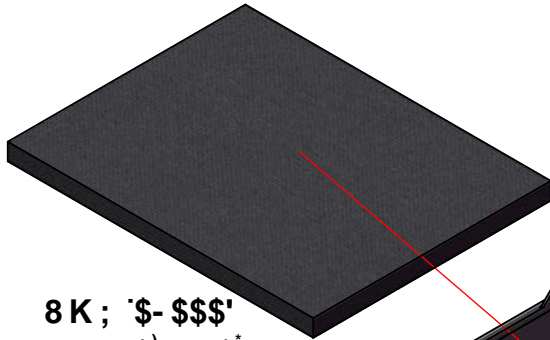

8K; '\$-\$\$\$'
 : C5A`%\$`r`%\$`

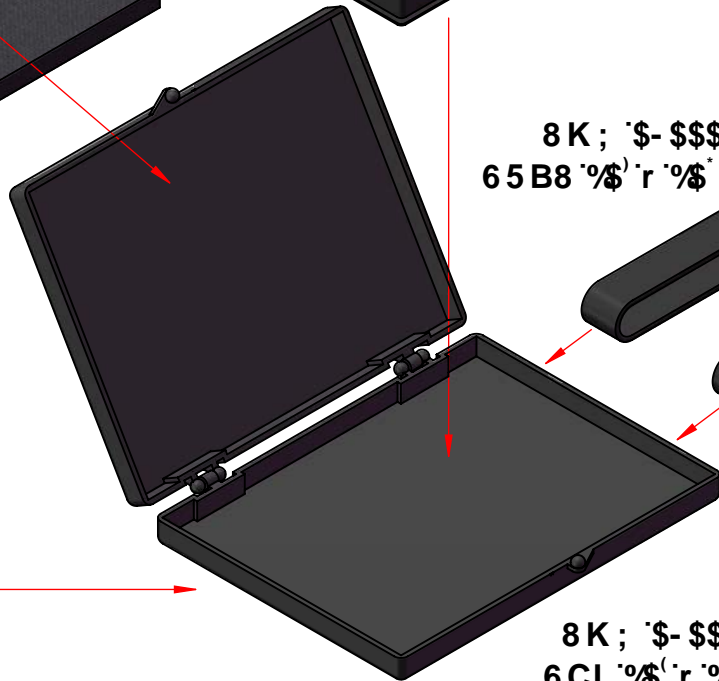

8K; '\$-\$\$\$)
 65B8`%\$`r`%\$`

71 GHCA9F.
 @69@

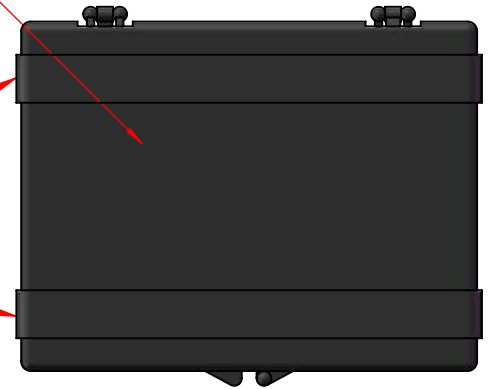

7 @CG98`6 CL

8K; '\$-\$\$\$-
 =BG9FH`%\$`%&



8K; '\$-\$\$\$
 6CL`%\$(`r`%\$`)

αβγδ	εζηθ			
ικλμ νξοπ ρστυ	φχψ ω			
αβγ δ εζη θ	ι κ λ μ ν ξ ο π ρ σ τ υ φ χ ψ ω	αβγδ	εζηθ	ι κ λ μ ν ξ ο π ρ σ τ υ φ χ ψ ω
αβγδ	εζηθ	ι κ λ μ ν ξ ο π ρ σ τ υ φ χ ψ ω	αβγδ	εζηθ
ι κ λ μ ν ξ ο π ρ σ τ υ φ χ ψ ω	αβγδ	εζηθ	ι κ λ μ ν ξ ο π ρ σ τ υ φ χ ψ ω	αβγδ
αβγδ	εζηθ	ι κ λ μ ν ξ ο π ρ σ τ υ φ χ ψ ω	αβγδ	εζηθ

AC89@
HCD

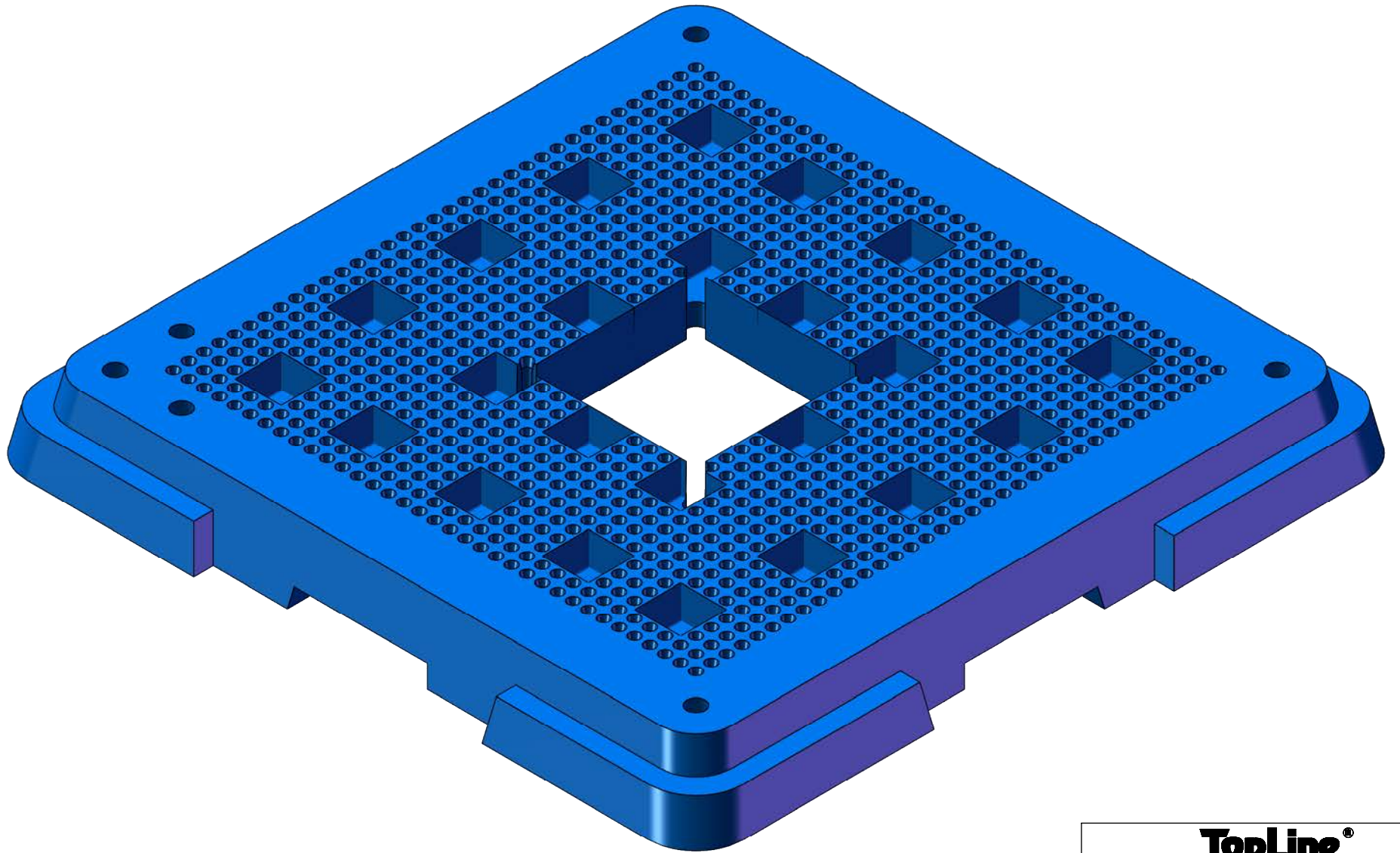

TopLine®			
ναιδὸ Ὀδὸσεῖ ἰάυσεῖ ἰούγ ὀσνω/ὀσεῖ/ὀου			
ὀσεῖ HF	ὀσεῖ CE	ὀσεῖ ὀσεῖ JHGHI	ὀσεῖ CE
ὀσεῖ ὀσεῖ ὀσεῖ ὀσεῖ			ὀσεῖ ὀσεῖ

HCD

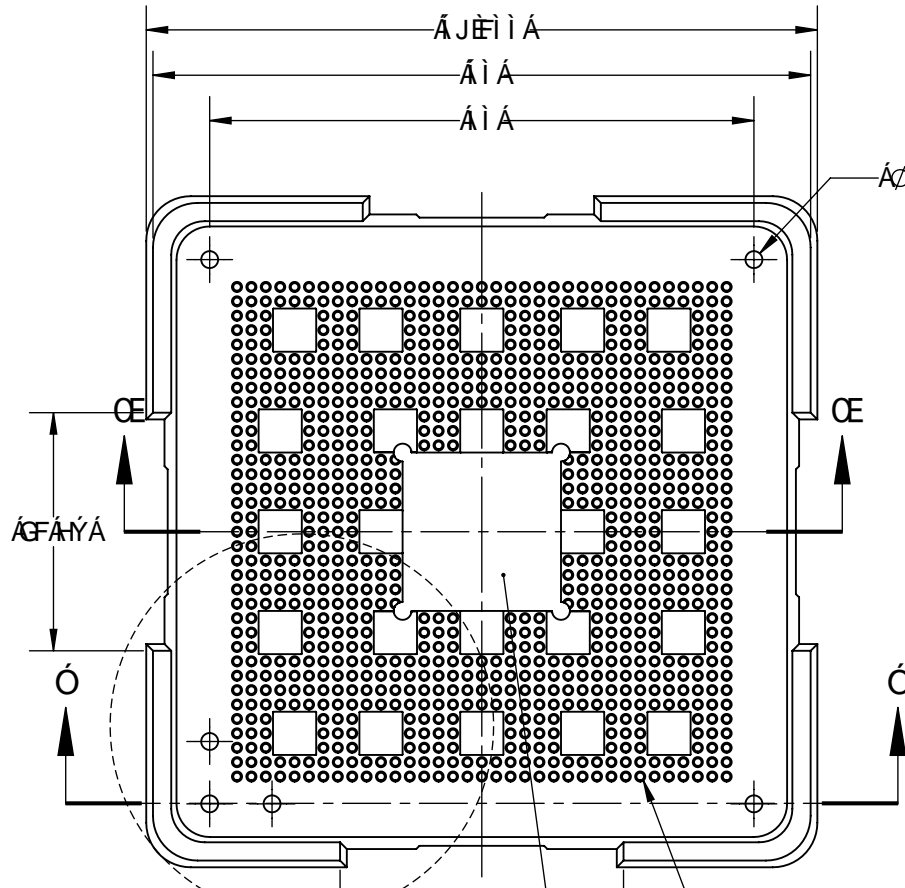

G89

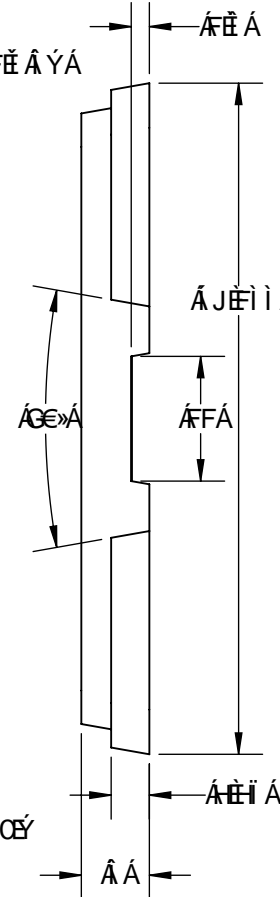

6CHCA

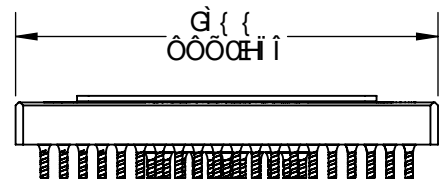
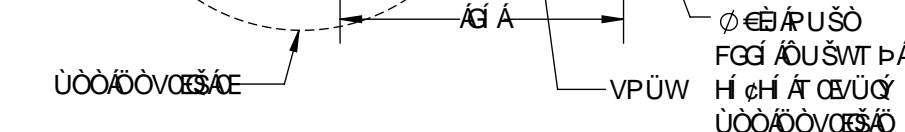
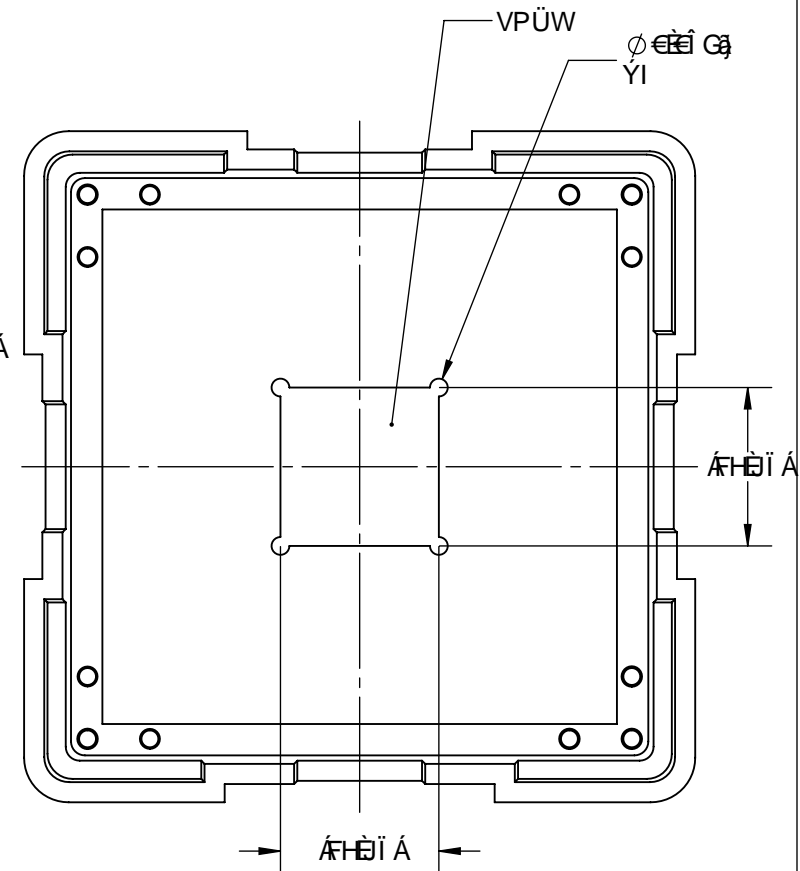

G97 HCB'5'15

$\dot{O}\dot{E}\dot{I}\dot{A}\dot{P}\dot{U}\dot{S}\dot{O}$
 $\dot{F}\dot{G}\dot{I}\dot{A}\dot{O}\dot{U}\dot{S}\dot{W}\dot{T}\dot{P}\dot{A}\dot{T}\dot{O}\dot{E}\dot{Y}$
 $\dot{H}\dot{I}\dot{C}\dot{H}\dot{I}\dot{A}\dot{T}\dot{O}\dot{E}\dot{U}\dot{O}\dot{Y}$
 $\dot{U}\dot{O}\dot{O}\dot{O}\dot{V}\dot{O}\dot{C}\dot{E}\dot{S}\dot{A}\dot{E}$

$\dot{P}\dot{U}\dot{V}\dot{O}\dot{U}\dot{K}$
 $\dot{F}\dot{E}\dot{O}\dot{O}\dot{P}\dot{U}\dot{O}\dot{P}\dot{A}\dot{T}\dot{E}$
 $\dot{C}\dot{A}\dot{T}\dot{O}\dot{E}\dot{V}\dot{O}\dot{U}\dot{O}\dot{E}\dot{S}\dot{K}\dot{O}\dot{S}\dot{W}\dot{A}\dot{O}\dot{O}\dot{U}\dot{A}\dot{J}\dot{O}\dot{U}\dot{T}\dot{O}\dot{E}\dot{V}\dot{N}\dot{O}\dot{E}\dot{I}\dot{A}\dot{E}\dot{E}$
 $\dot{H}\dot{E}\dot{A}\dot{V}\dot{O}\dot{T}\dot{U}\dot{O}\dot{U}\dot{O}\dot{E}\dot{W}\dot{U}\dot{O}\dot{A}\dot{E}\dot{A}\dot{T}\dot{O}\dot{E}\dot{Y}$
 $\dot{I}\dot{E}\dot{A}\dot{T}\dot{O}\dot{E}\dot{U}\dot{A}\dot{F}\dot{I}\dot{E}\dot{A}\dot{O}\dot{U}\dot{O}\dot{E}\dot{U}\dot{E}$
 $\dot{I}\dot{E}\dot{A}\dot{J}\dot{O}\dot{U}\dot{T}\dot{O}\dot{E}\dot{P}\dot{O}\dot{P}\dot{V}\dot{A}\dot{O}\dot{U}\dot{O}\dot{A}\dot{E}\dot{V}\dot{O}\dot{E}\dot{V}\dot{N}\dot{O}\dot{E}\dot{O}\dot{A}\dot{A}$
 $\dot{I}\dot{E}\dot{A}\dot{J}\dot{W}\dot{U}\dot{O}\dot{O}\dot{O}\dot{A}\dot{U}\dot{O}\dot{U}\dot{O}\dot{V}\dot{Q}\dot{Y}\dot{A}\dot{E}\dot{F}\dot{E}\dot{d}\dot{F}\dot{E}\dot{F}\dot{G}\dot{A}$

TopLine[®]

VASO $\dot{O}\dot{O}\dot{O}\dot{C}\dot{H}\dot{I}\dot{A}\dot{U}\dot{O}\dot{E}\dot{Y}\dot{O}\dot{U}\dot{Y}$ $\dot{O}\dot{S}\dot{W}\dot{A}\dot{O}\dot{O}\dot{E}\dot{U}\dot{O}\dot{U}$			
UOCESO HG	UAO CE	OUY AOAPUE JHGHI	UOX CE
OUPUVAVUCESO OUY AO		UPONOAHUCAF	

89H5=@8

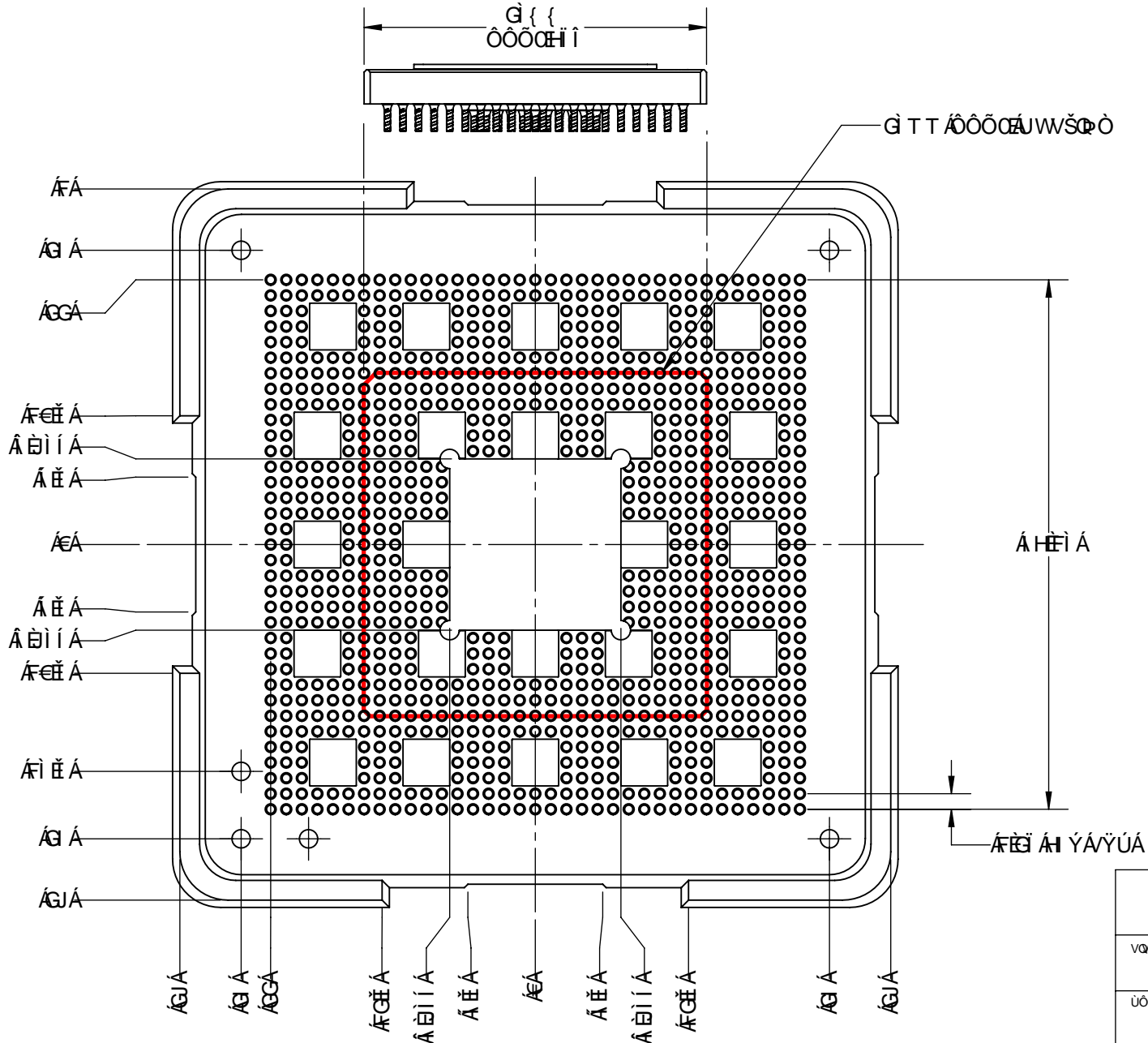

ΠΥΛΟΥΚ
ΑΞΙΟΓΡΑΦΟΥ ΠΑΤΕ

TopLine®			
ΜΑΡΚΑ ΟΡΓΑΝΙΣΜΟΣ ΑΥΤΟΚΑΤΑΡΤΙΣΤΩΝ ΟΣΩΟΑΕΥΣΟΥ			
ΜΑΡΚΑ ΓΚ	ΜΑΡΚΑ ΓΕ	ΜΑΡΚΑ ΟΡΓΑΝΙΣΜΟΣ ΑΥΤΟΚΑΤΑΡΤΙΣΤΩΝ ΟΣΩΟΑΕΥΣΟΥ	ΜΑΡΚΑ
ΟΡΓΑΝΙΣΜΟΣ ΑΥΤΟΚΑΤΑΡΤΙΣΤΩΝ			ΥΠΟΒΑΛΟΥΣΑ

HCD'fCD9BŁ

G89`J=9K`fCD9BŁ

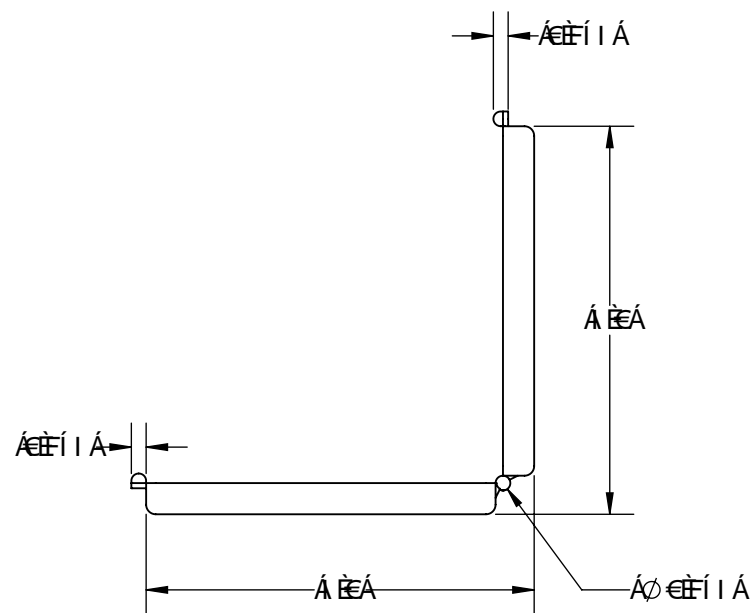
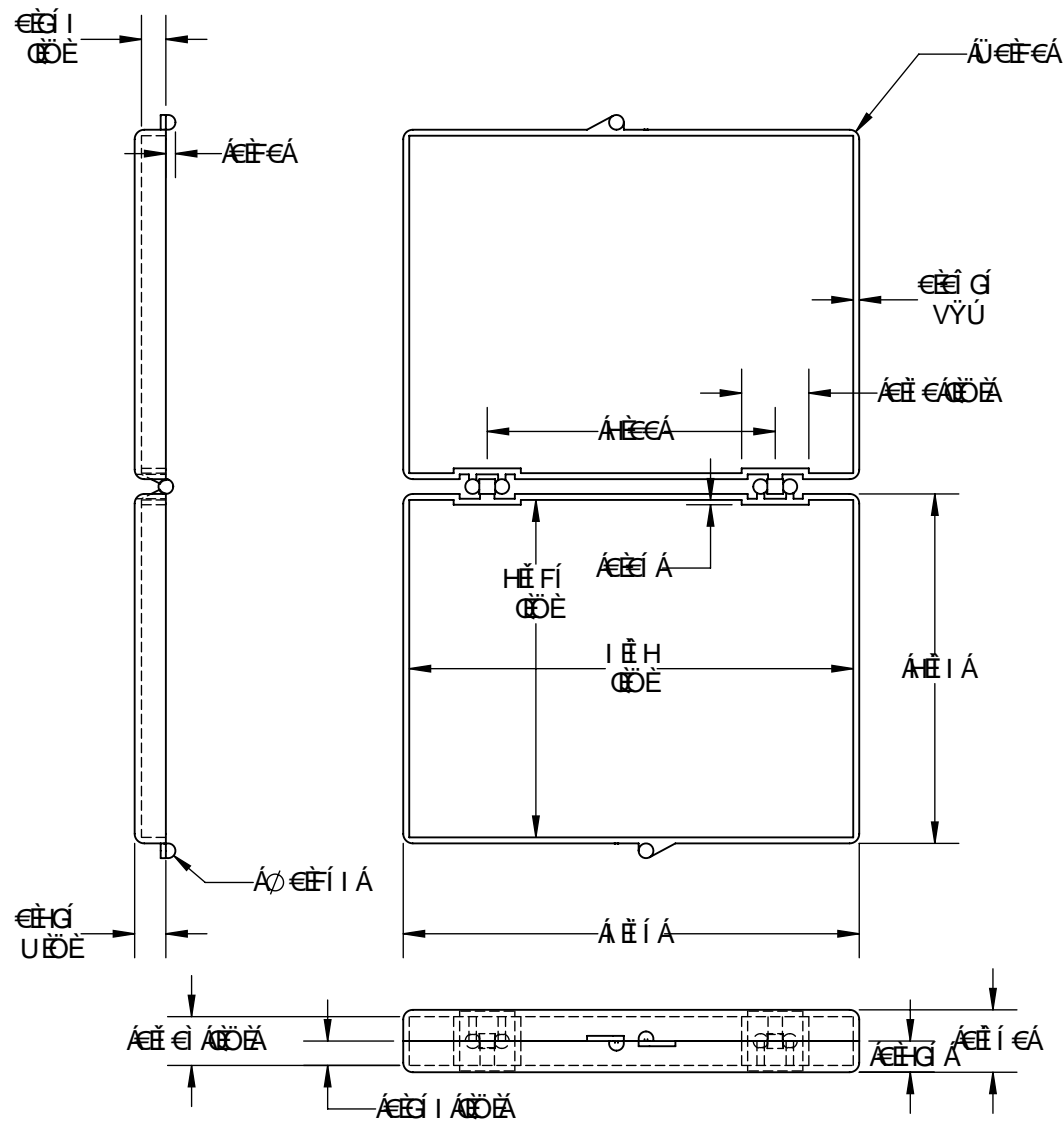

AC89@

: FCBH'f7 @CG98Ł

Π [c•kV | •• Á @ ! , a ^ Á J ^ 8aa a È
 ΔÜWÜØØÄÜØÜØVXQYKfÉÁfÉ È
 GA T αVØÜØS'KØÜØÜØP ÁØSØÖÄÜSÝÜÜUÜYŠØP ØÈ
 HDÜQ ØP ÜØP ÜÁ Ø P Ø P Ø ÜÈ

TopLine[®]			
ναsò	ÒØFÀØT ÙVÝÁØYD PØØØØUY		
ÙÒαSØ FIG	ÙαØ ØE	ØÜæ Ø Ø Ø ÜÈ €J€€€€	ÙØX ØE
ØÜØVÜØØSØØÜæ Ø Ø			ÙPØØVÁ ÜØØf€

ΓΕΝΙΚΑ
 ΟΣΥΝΟΛΟ
 ΣΥΝΑΡΤΗΣΗ

HCD J-9K

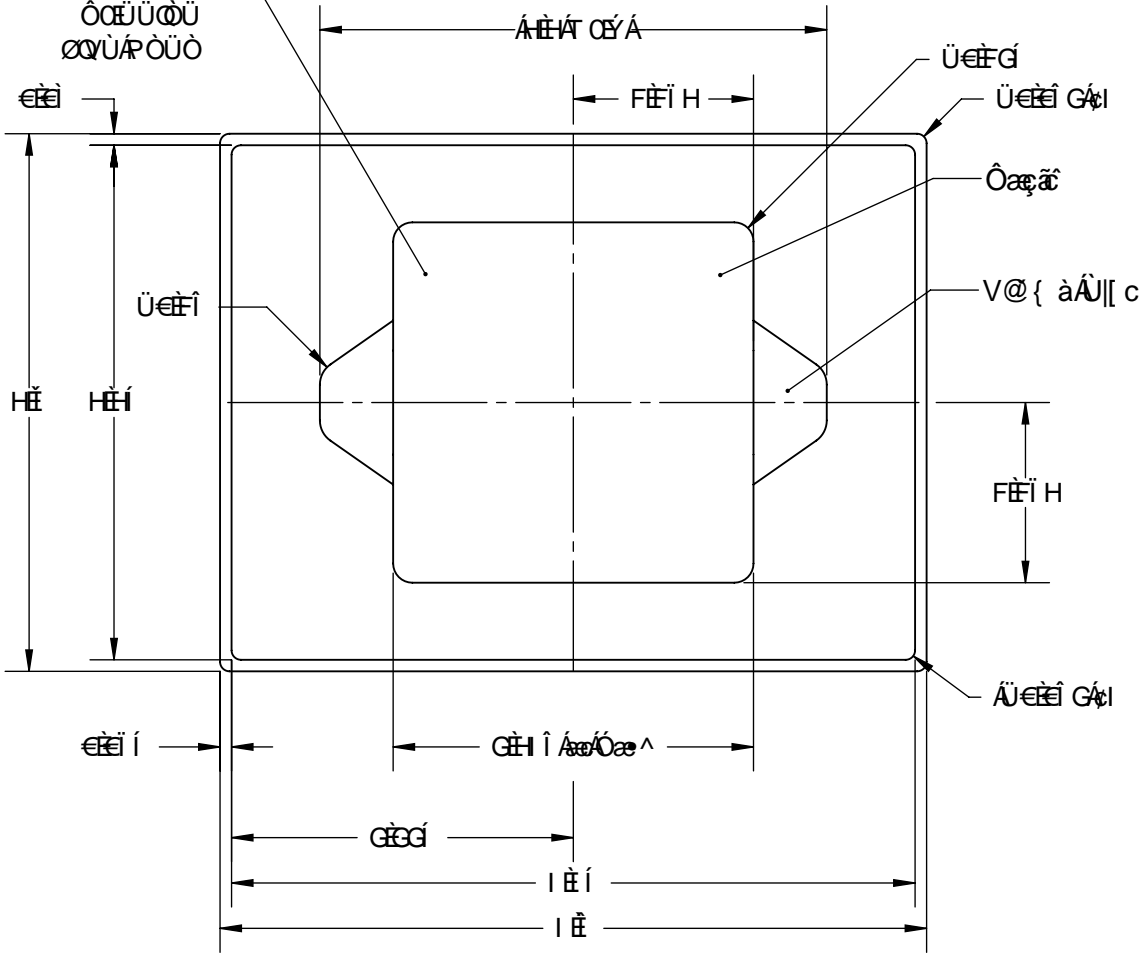

6 CHCA J-9K

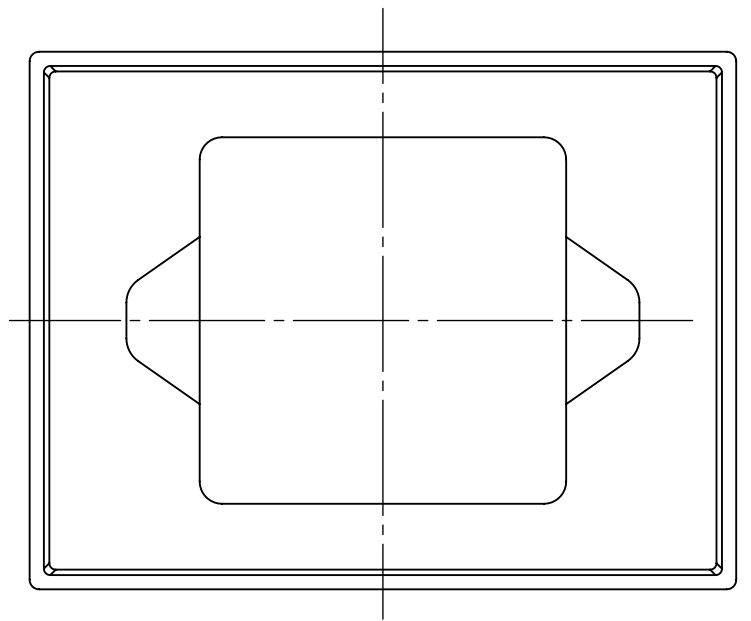

G-89 J-9K

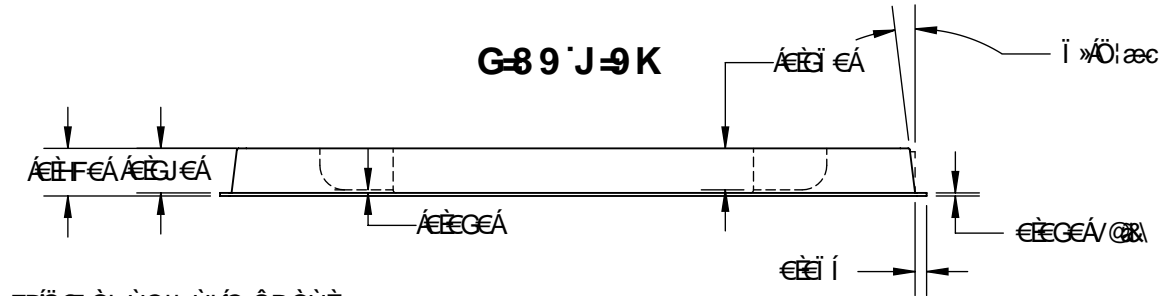

AC89@

FDÖQ ÒPÜQ PÜKQ ÒPÒÈ
 GDÄ ÇVÖÜQSKÖUPÖMÖVQÖÄVYÜÖPÖÈ
 HDÜWÜQÖÖÜÖÜQVQYÄ FÉ È

TopLine®			
vαsò ÔÖÖQVÜCYÄ PÜÖY QUA È Γ AÆ PÖÖQY			
UÖCSÖ GGÉ	UQZÖ CE	OUQY PÖPUE FI ΕFFE	UOX CE
ÖUAPUVÄÜCSÖPÜQY PÖ			ÜPÖÖVÄ ÜQÆE

HCD

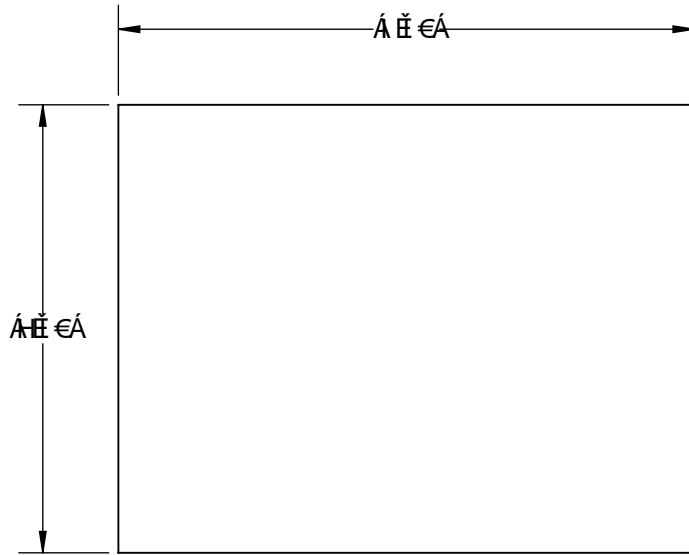

98; 9

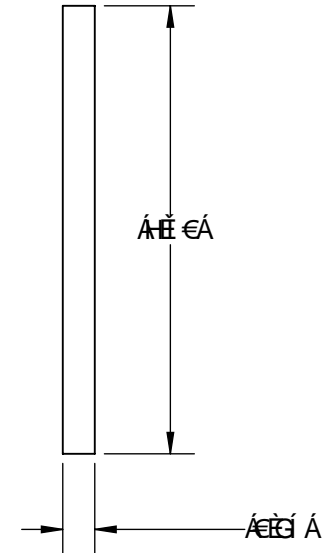

G89

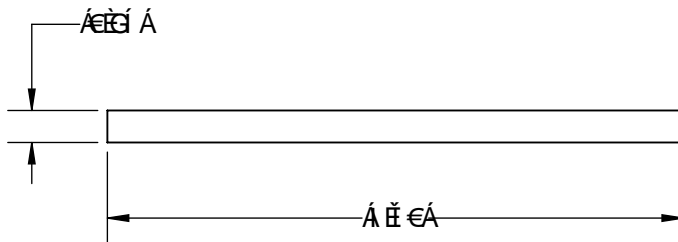

ΠΡΟΣΦΕΡΟΜΕΝΕΣ ΔΙΑΔΙΟΡΜΕΣ
 ΕΠΙΣΤΡΟΦΗ ΕΙΣ ΤΟΝ ΠΡΟΪΟΝΤΑ
 ΕΠΙΣΤΡΟΦΗ ΕΙΣ ΤΟΝ ΠΡΟΪΟΝΤΑ
 ΕΠΙΣΤΡΟΦΗ ΕΙΣ ΤΟΝ ΠΡΟΪΟΝΤΑ

TopLine®

ΤΥΠΟΣ ΠΡΟΪΟΝΤΟΣ ΣΥΝΘΕΣΗ			
ΤΥΠΟΣ FHE	ΤΥΠΟΣ CE	ΤΥΠΟΣ ΠΡΟΪΟΝΤΟΣ ΕΥΡΩΠΑΪΚΟ	ΤΥΠΟΣ CE
ΟΡΓΑΝΙΣΜΟΣ ΠΡΟΪΟΝΤΟΣ		ΠΡΟΪΟΝΤΑ ΕΥΡΩΠΑΪΚΗΣ	

HCD

98; 9

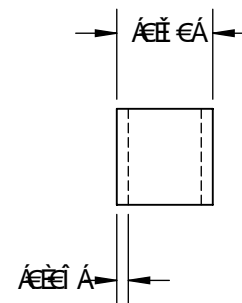
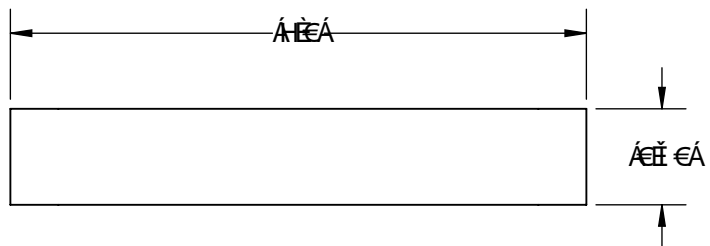

G-89

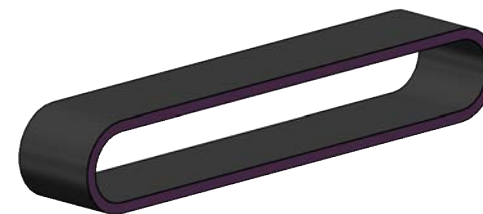
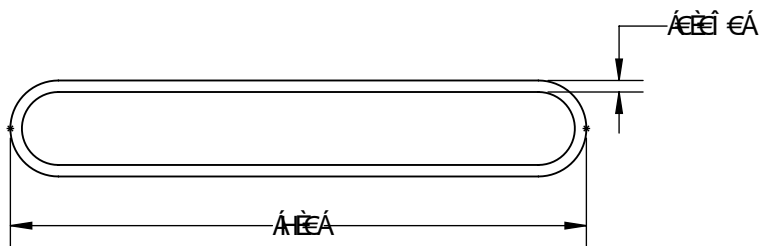

AC89@

Ρ [ε • κ ω] ^ • • Α υ @ ! , α ^ Α] ^ & α α α ε
 F Δ U W Z O O Α Ξ Ο U Q V X Q Y K F € ο Α U Α € ο Ε
 G Δ Q O P U Q P U A A P O P O U A C J O U V O O Α U U Q W P E

TopLine®			
ν α ρ σ ο Ξ Υ W O O U J A C E P O H E E O O S A O S A O U P O W O N Q X O			
υ ο α σ ο FKF	υ α ρ ο CE	ο υ α ρ ο φ ο λ υ ε € J E E I	υ ο x CE
ο υ α ρ ο ν υ λ ο α σ ο φ ο λ υ ε φ ο			υ π ο ο ν α λ υ α ρ ε

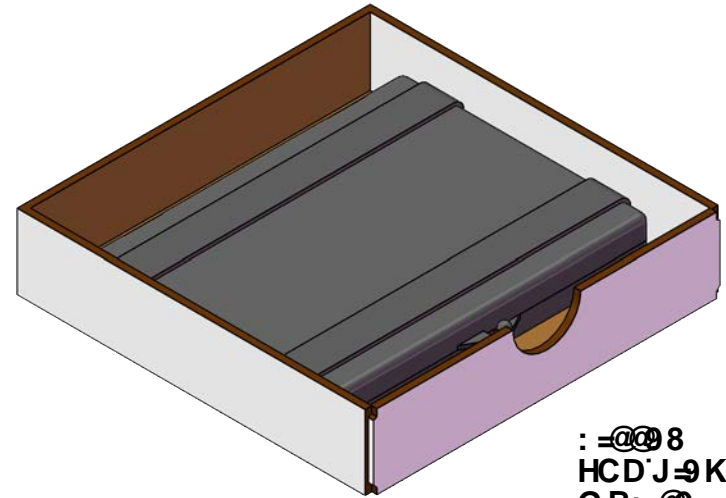
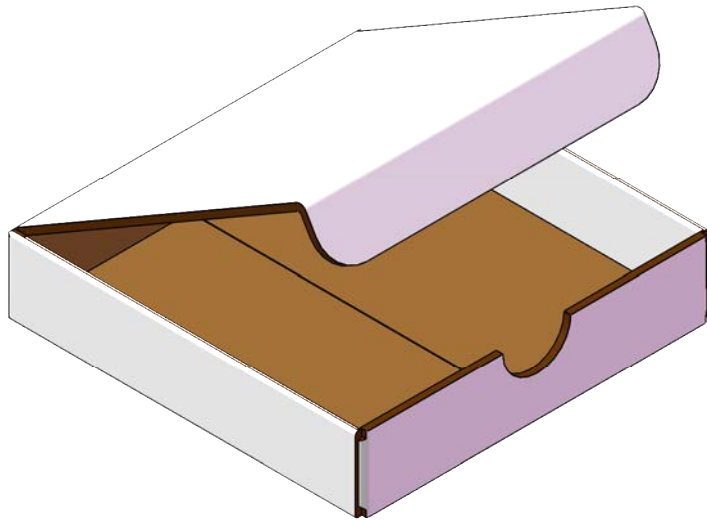

: =@@8
HCD'J→K
G-B; @

ΒΥΝΟΥΚΩ, Λ••Αΐ@!, α^ΑΐJ ^8aa aDE
ΑΕΩQ ΟΡΪΦΠΥΑΦ ΟΡΟΥΕ
ΑΓΑΤ ΟΟΕΜΪΟΤ ΟΡΥΑΦ ΟΣΪΩΟΪΑΪΪΩΟΪΑΪΟΟΕ ΟΪΕ
ΑΕΩΥΑΪΖΟΑΪΪΩΟΡΟΪΑΪΑΪΟΡΟΕ

TopLine®			
VARSO ÔÔÔCÄVÜCÿ/OUÝ/ÔCÿÜÜÜ OÖÿVUP			
ÜOCSO FKG	ÜAZO CE	ÜÜCÿ QÖÄUE JEEEEF	ÜÜX CE
ÖUÄUVÄÜOCSOÖÜCÿ QÖ		ÜPÖÖNÄEÄÜZÄE	