

EXPLODED VIEW CCGA TRAY BOX SYSTEM 1.0MM PITCH

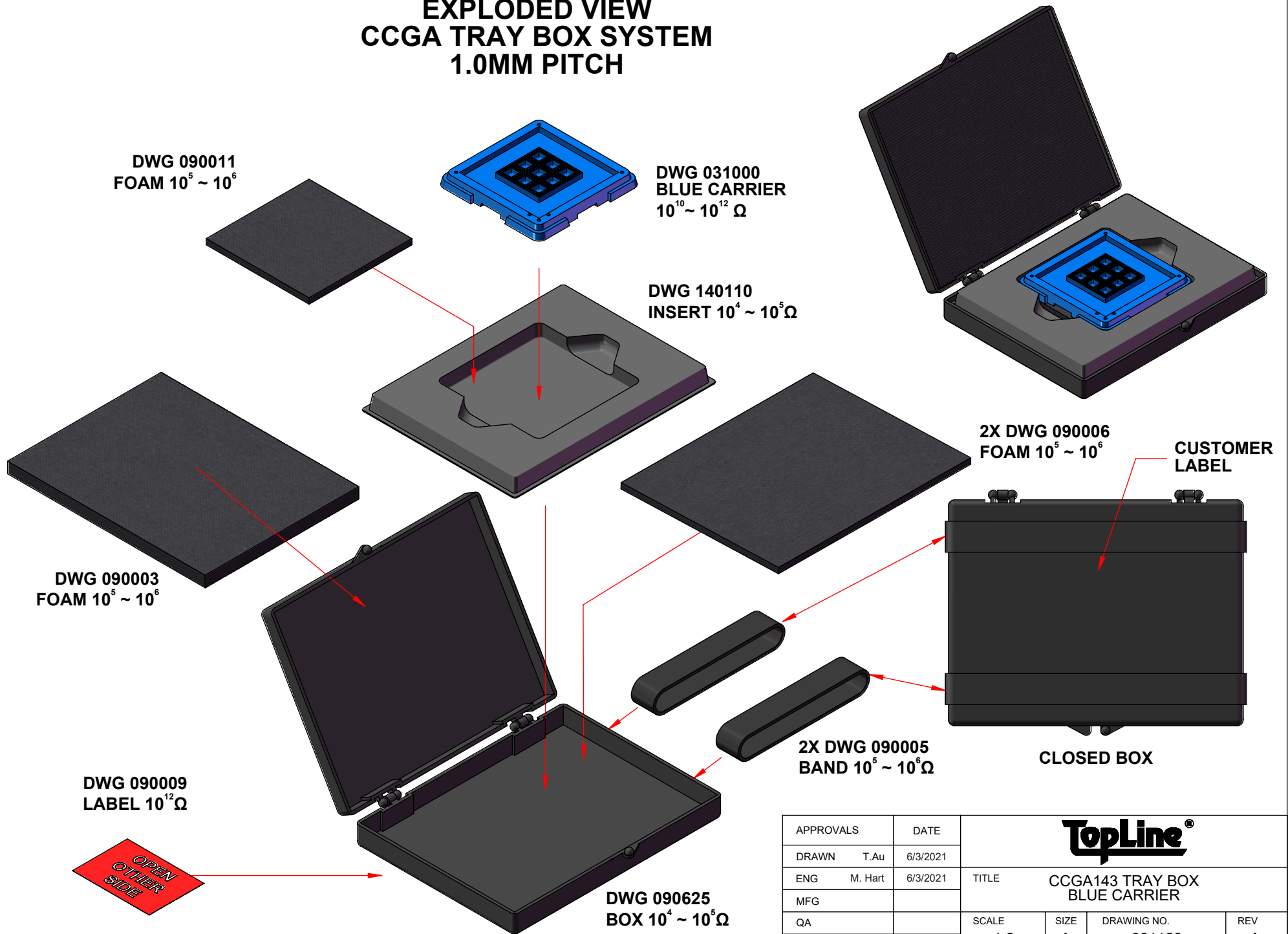

APPROVALS	DATE	TopLine®			
DRAWN T. Au	6/3/2021				
ENG M. Hart	6/3/2021	TITLE CCGA143 TRAY BOX BLUE CARRIER			
MFG		SCALE	SIZE	DRAWING NO.	REV
QA		1:2	A	931129	A
CUST		DO NOT SCALE DRAWING			SHEET 1 OF 12
REVISED					

MODEL
TOP

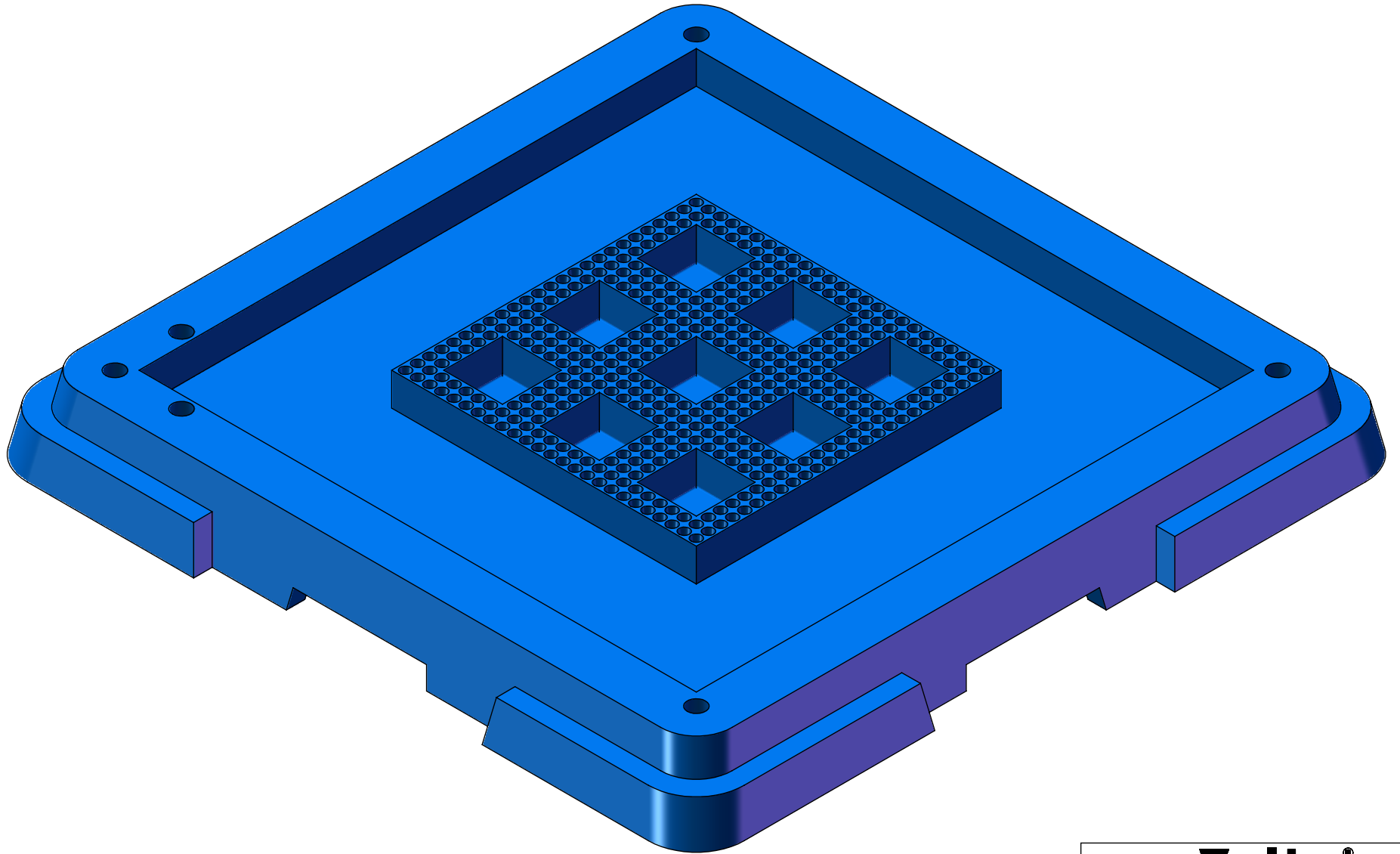

TopLine®

TITLE CCGA143 TRAY BOX
BLUE CARRIER

SCALE 3:1	SIZE A	DRAWING NO. 931129	REV A
--------------	-----------	-----------------------	----------

DO NOT SCALE DRAWING

SHEET 2 OF 12

TOP

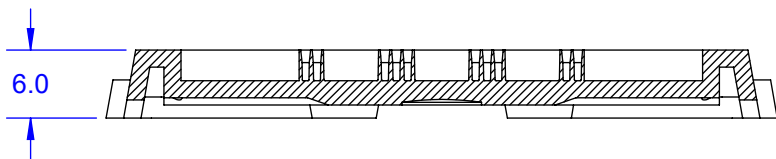
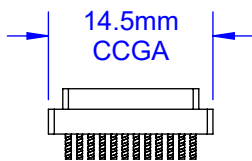
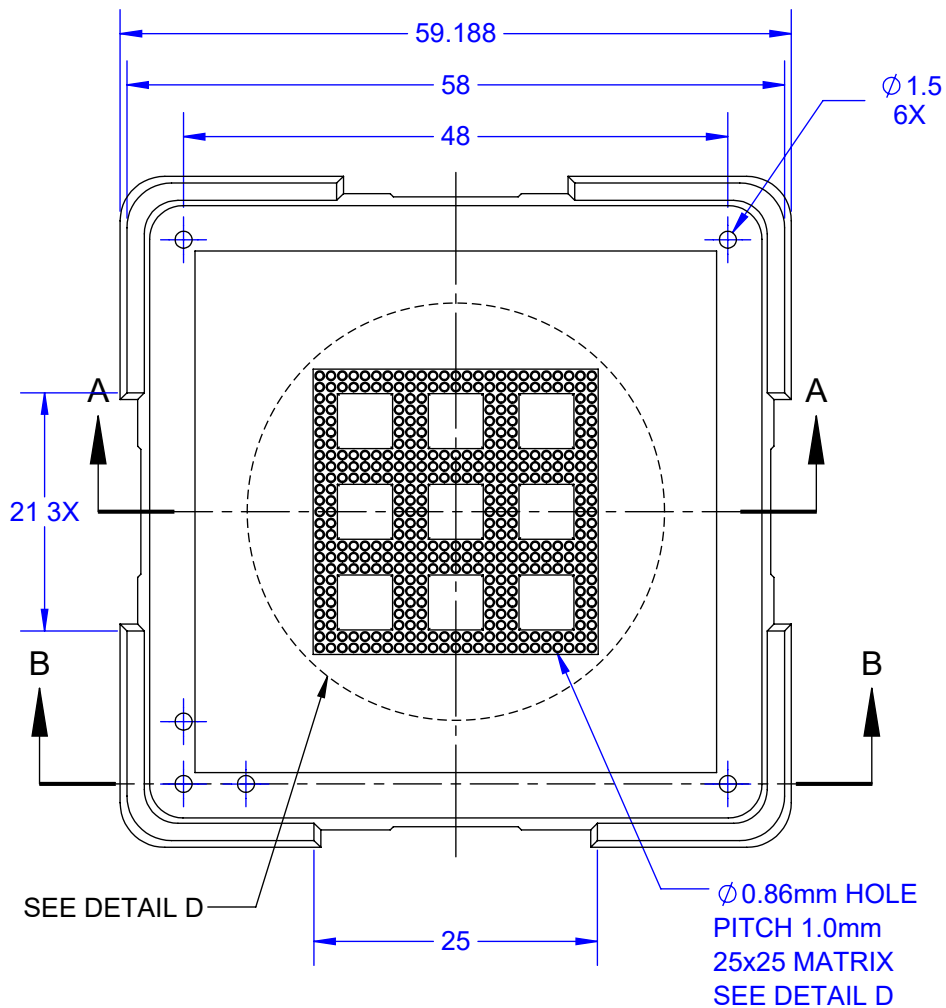

SECTION A-A

SIDE

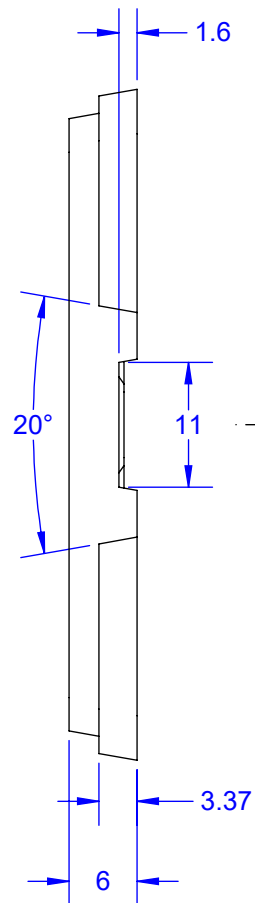

BOTTOM

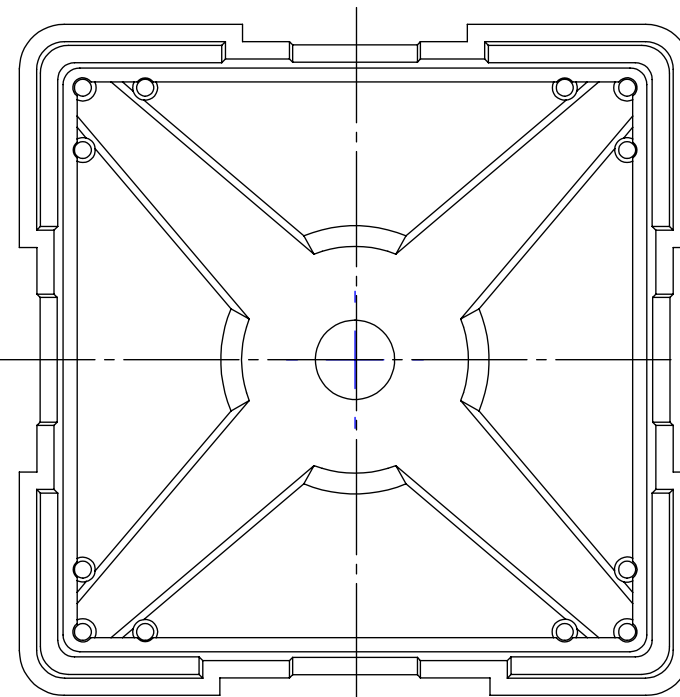

- Notes: (Unless Otherwise Specified).
1. DIMENSIONS MM.
 2. MATERIAL: BLUE ABS PERMASTAT® 600.
 3. TEMPERATURE 60° MAX.
 4. MASS 10.3 GRAMS.
 5. PERMANENT ESD ANTI-STATIC
 6. SURFACE RESISTIVITY $10^{10} \sim 10^{12} \Omega$

TopLine®

TITLE			
CCGA143 TRAY BOX BLUE CARRIER			
SCALE	SIZE	DRAWING NO.	REV
3:2	A	931129	A
DO NOT SCALE DRAWING			SHEET 3 OF 12

DETAIL D

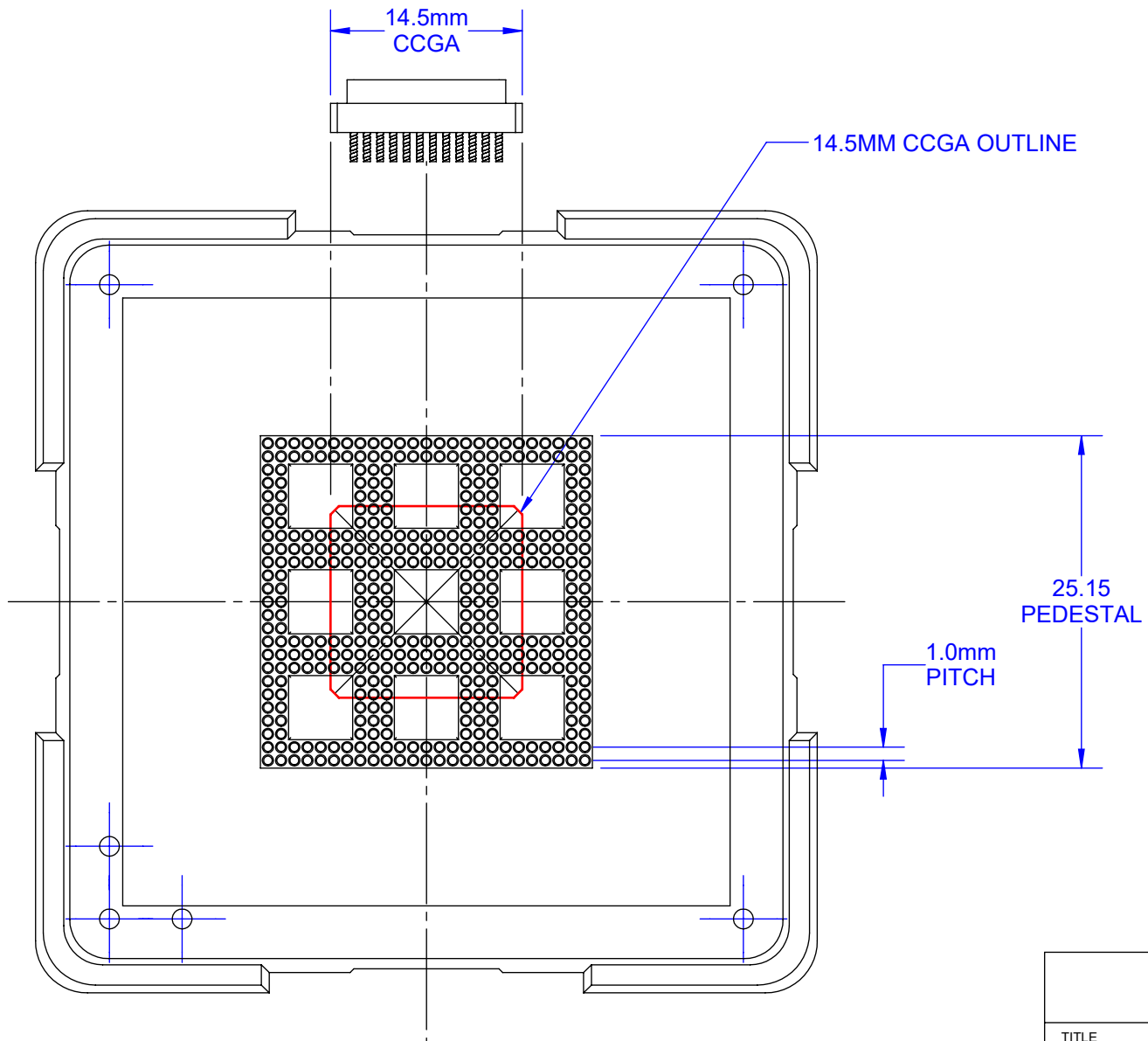

Notes: (Unless Otherwise Specified).

1. DIMENSIONS MM.
2. NOT TO SCALE

TopLine®			
TITLE		CCGA143 TRAY BOX BLUE CARRIER	
SCALE	SIZE	DRAWING NO.	REV
2:1	A	931129	A
DO NOT SCALE DRAWING			SHEET 4 OF 12

TOP (OPEN)

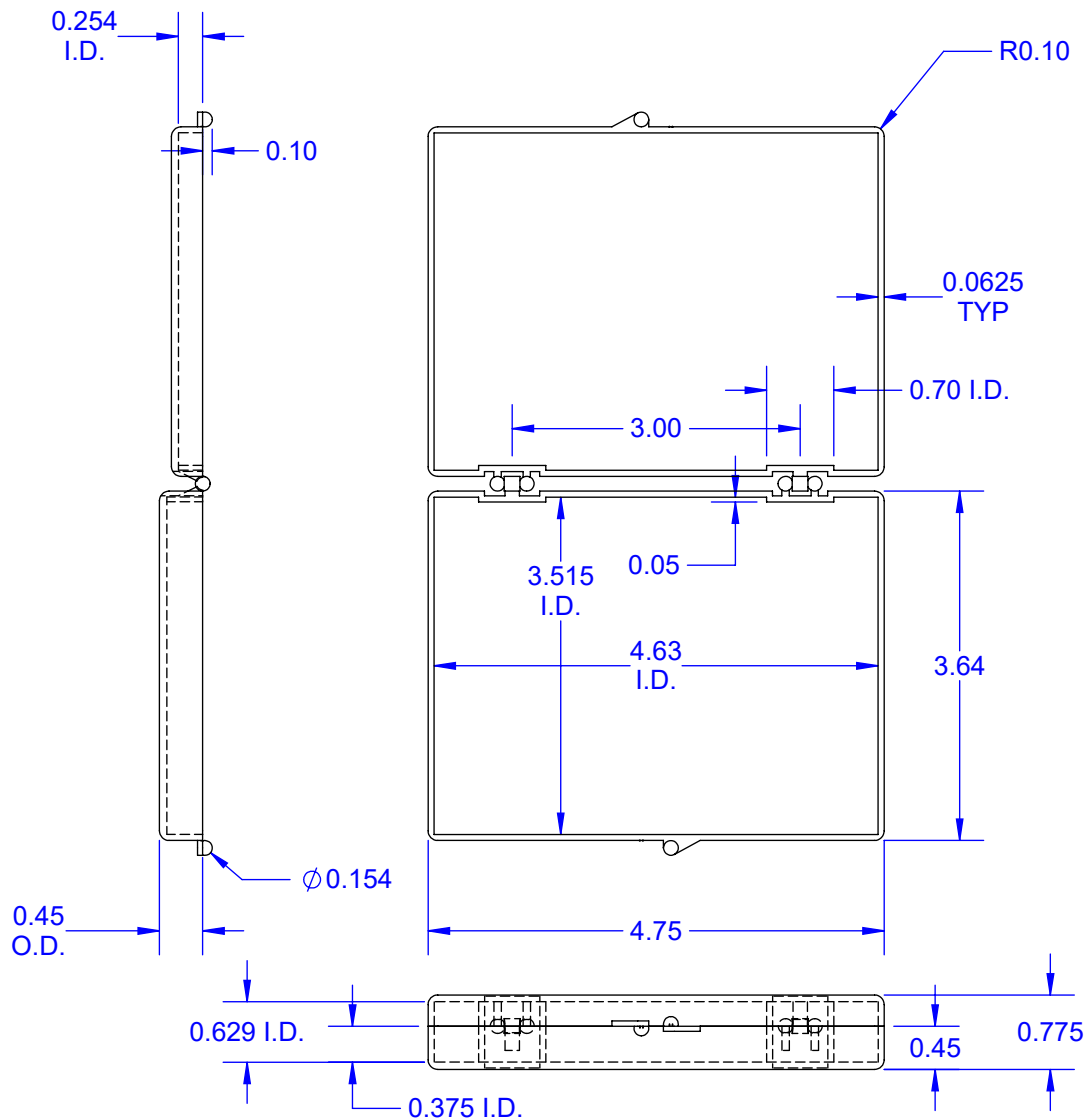

FRONT (CLOSED)

SIDE VIEW (OPEN)

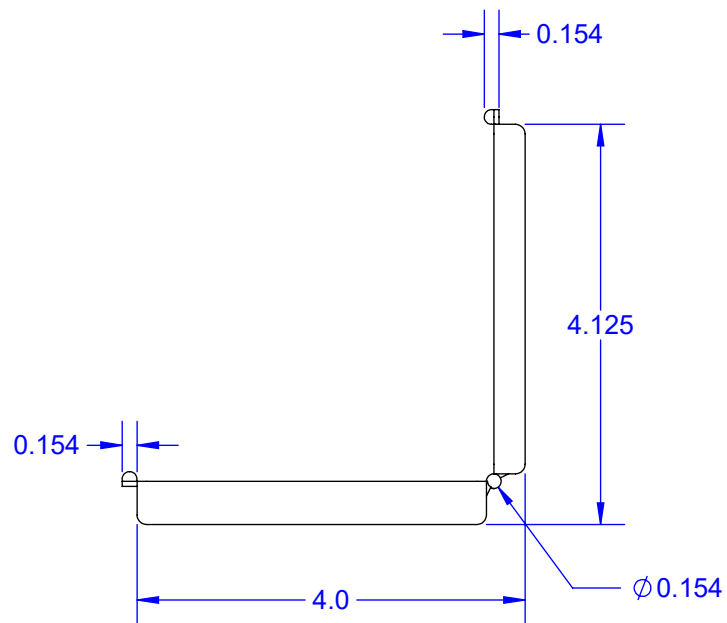

MODEL

Notes: (Unless Otherwise Specified).

- 1) SURFACE RESISTIVITY: $10^4 \sim 10^5 \Omega$.
- 2) MATERIAL: CARBON FILLED POLYPROPYLENE.
- 3) DIMENSIONS IN INCHES.

TopLine®			
TITLE		EC1-15mm EMPTY HINGE BOX	
SCALE	SIZE	DRAWING NO.	REV
1:2	A	090625	A
DO NOT SCALE DRAWING			SHEET 5 OF 12

TOP VIEW

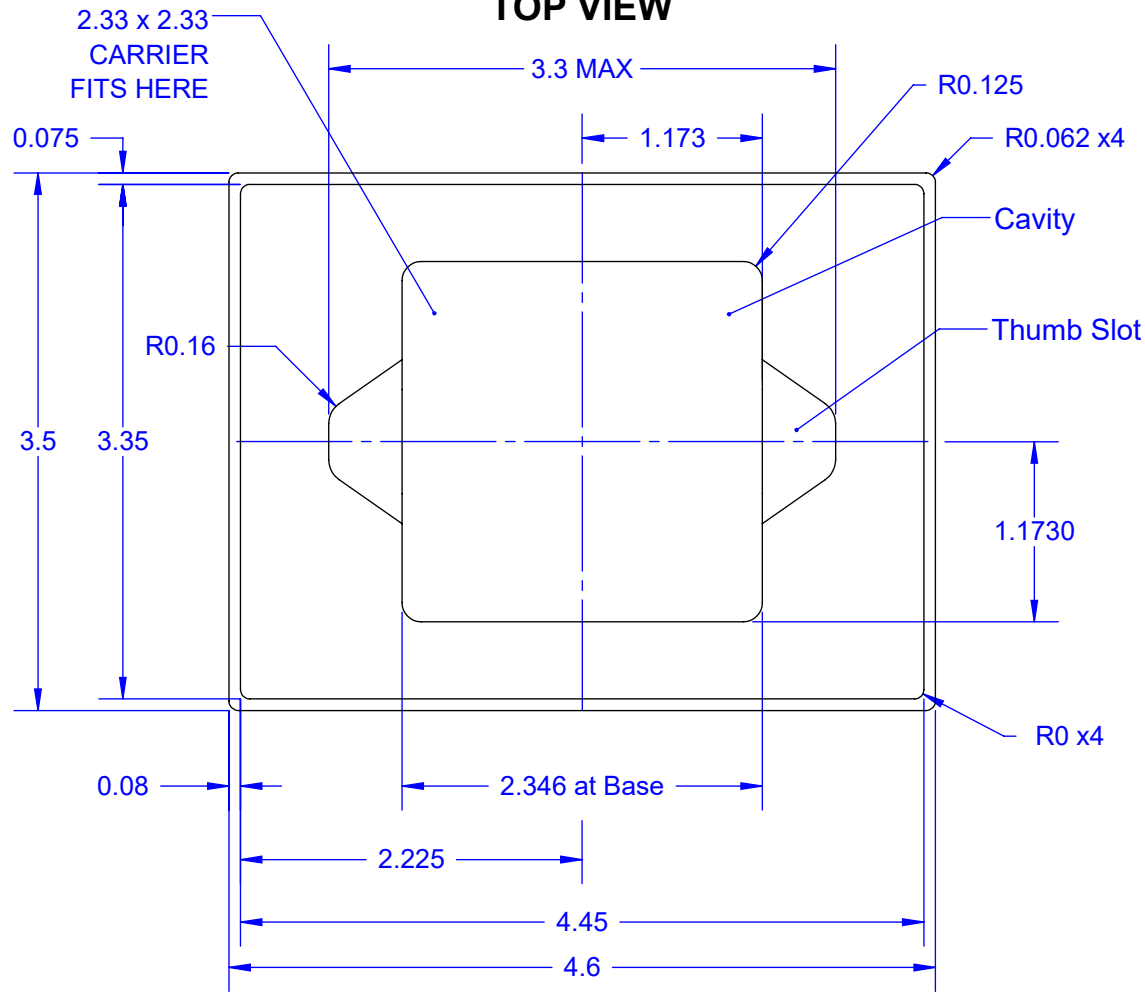

BOTTOM VIEW

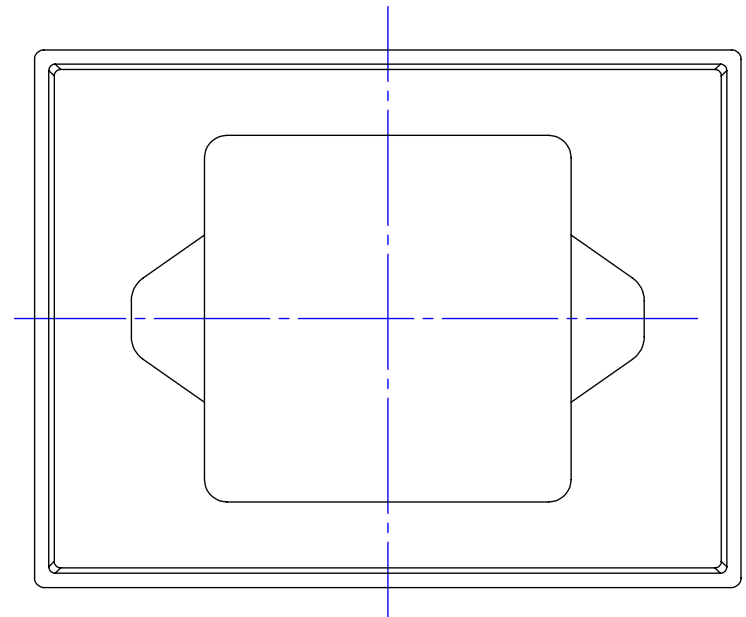

SIDE VIEW

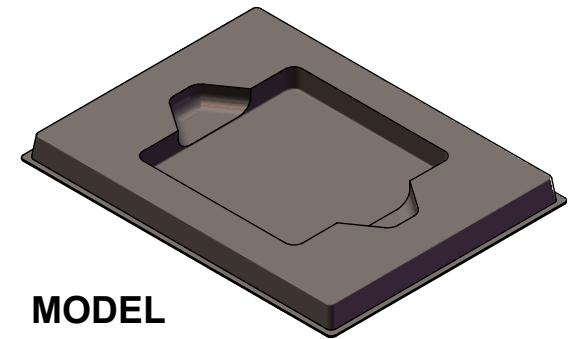
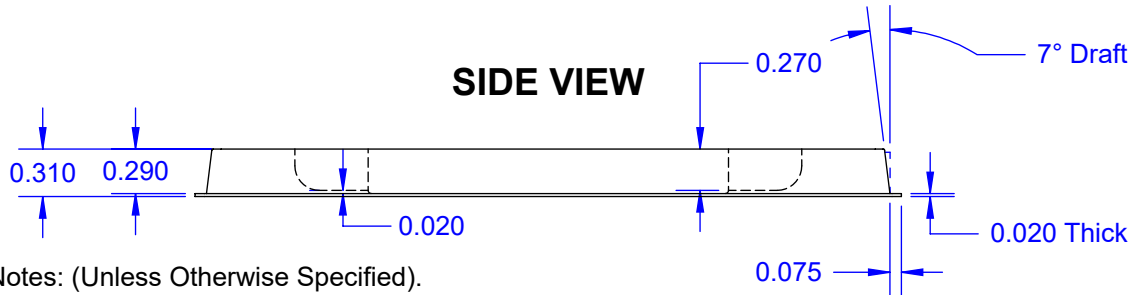

MODEL

Notes: (Unless Otherwise Specified).

- 1) DIMENSIONS: INCHES.
- 2) MATERIAL: CONDUCTIVE STYRENE.
- 3) SURFACE RESISTIVITY <math>< 10^4 \Omega</math>.

TopLine®

TITLE CCGA TRAY INSERT
FOR 4.625 x 3.5 HINGE BOX

SCALE	SIZE	DRAWING NO.	REV
2:2.5	A	140110	A

DO NOT SCALE DRAWING

SHEET 6 OF 12

TOP

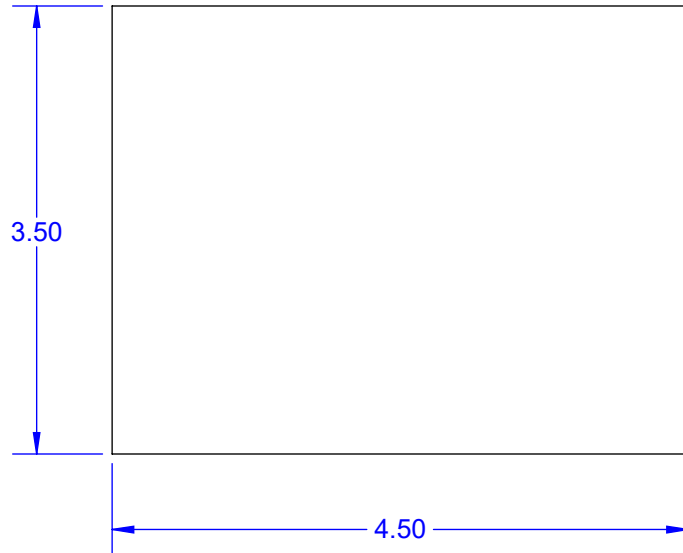

EDGE

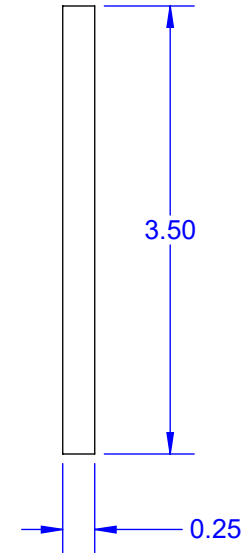

SIDE

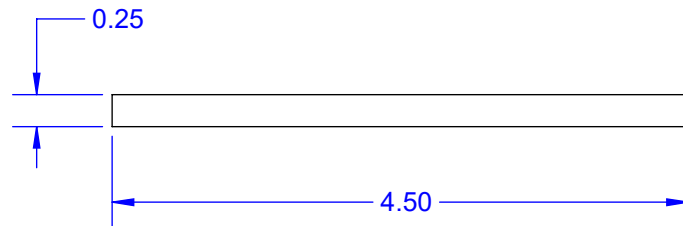

MODEL

- Notes: (Unless Otherwise Specified).
- 1) SURFACE RESISTIVITY: $10^5 \sim 10^6 \Omega$
 - 3) DENSITY 1.7 PFC Min.
 - 4) DIMENSIONS IN INCHES.

TopLine®			
TITLE		EC1-FOAM-SOFT-.25-A LOW DENSITY FOAM	
SCALE	SIZE	DRAWING NO.	REV
1:1.5	A	090003	A
DO NOT SCALE DRAWING			SHEET 7 OF 12

TOP

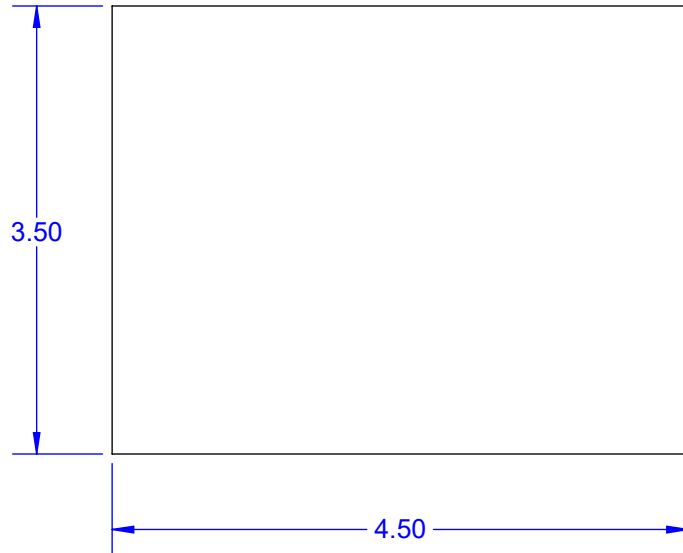

EDGE

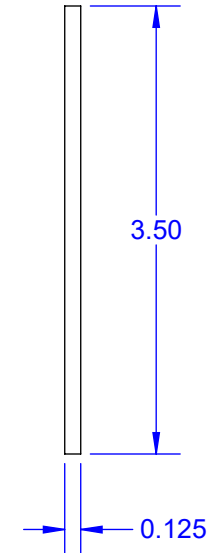

SIDE

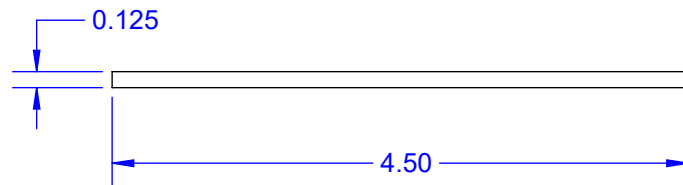

MODEL

- Notes: (Unless Otherwise Specified).
 1) SURFACE RESISTIVITY: $10^5 \sim 10^6 \Omega$
 3) DENSITY 1.7 PFC Min.
 4) DIMENSIONS IN INCHES.

TopLine®			
TITLE EC1-FOAM-SOFT-.125-A LOW DENSITY FOAM			
SCALE 1:1.5	SIZE A	DRAWING NO. 090006	REV A
DO NOT SCALE DRAWING			SHEET 8 OF 12

TOP

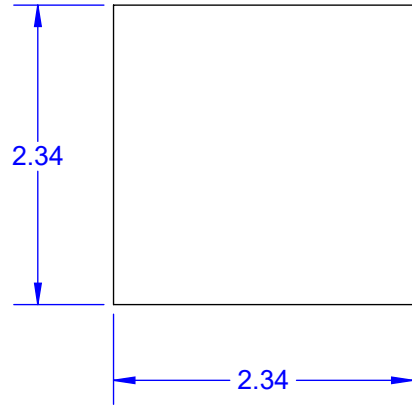

EDGE

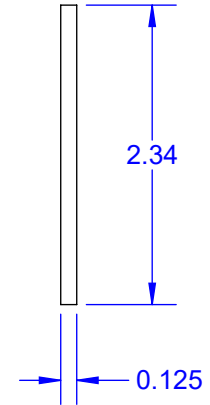

SIDE

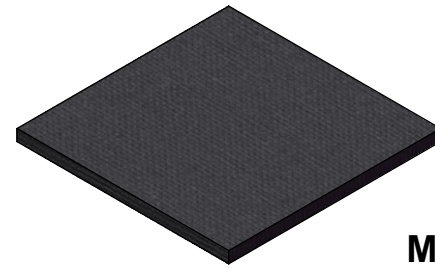
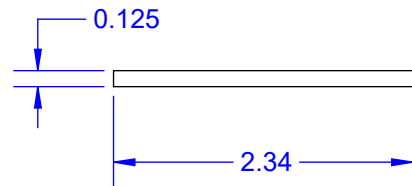

MODEL

- Notes: (Unless Otherwise Specified).
- 1) SURFACE RESISTIVITY: $10^5 \sim 10^6 \Omega$.
 - 2) SOFT CONDUCTIVE FOAM.
 - 3) DENSITY 1.7 PFC Min.

TopLine®			
TITLE		LOW DENSITY FOAM FOAM-SOFT-2.34A	
SCALE	SIZE	DRAWING NO.	REV
1:1.5	A	090011	A
DO NOT SCALE DRAWING			SHEET 9 OF 12

TOP

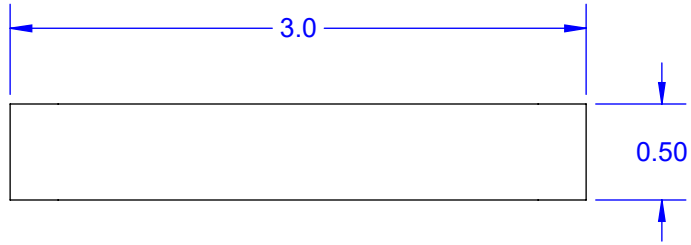

EDGE

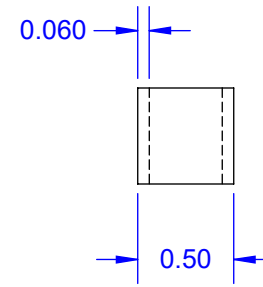

SIDE

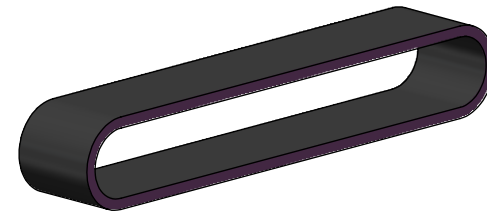
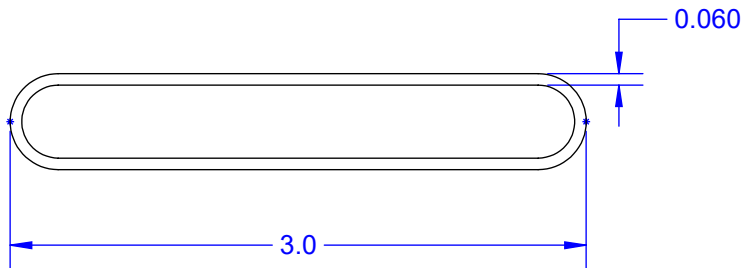

MODEL

Notes: (Unless Otherwise Specified).

1) SURFACE RESISTIVITY: $10^5 \sim 10^6$.

2) DIMENSIONS IN INCHES (RESTING POSITION).

TopLine[®]

TITLE RUBBER BAND-3.0-C
BLACK CONDUCTIVE

SCALE	SIZE	DRAWING NO.	REV
1:1	A	090005	A

DO NOT SCALE DRAWING

SHEET 10 OF 12

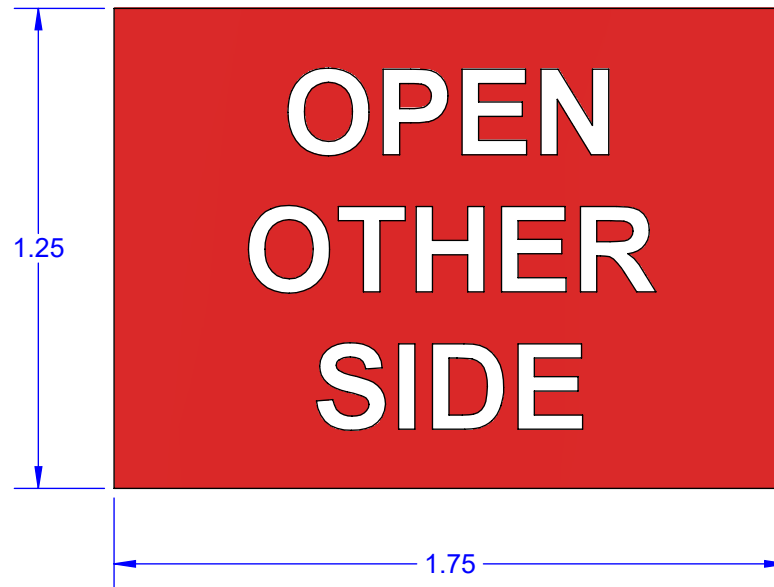

Notes: (Unless Otherwise Specified).

1. DIMENSIONS INCHES.
2. MATERIAL: PAPER LABEL WITH ADHESIVE.
3. COLOR: RED.
4. PURPOSE: IDENTIFY BOTTOM OF HINGE BOX.

TopLine®			
TITLE		LABEL FOR BOTTOM OF HINGE BOX	
SCALE	SIZE	DRAWING NO.	REV
2:1	A	090009	A
DO NOT SCALE DRAWING			SHEET 11 OF 12

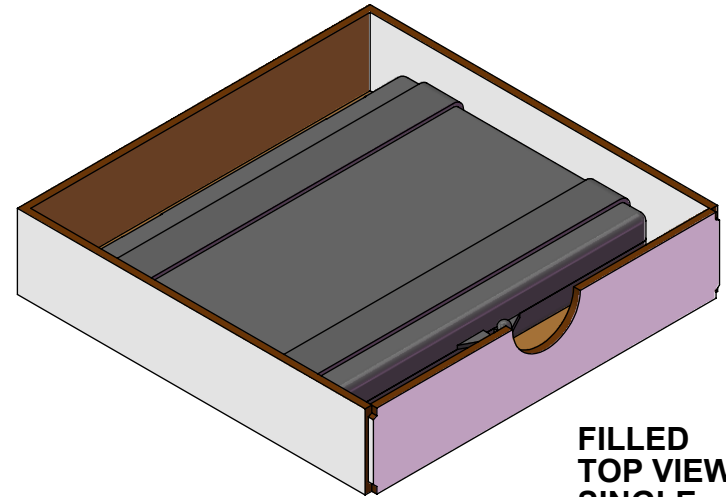
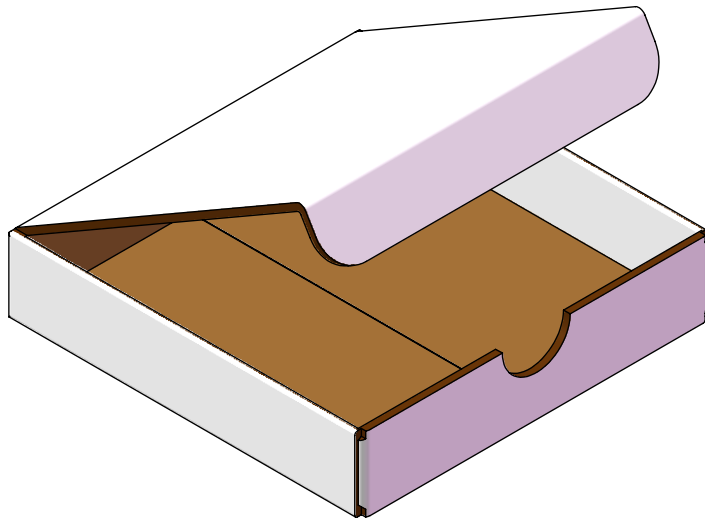
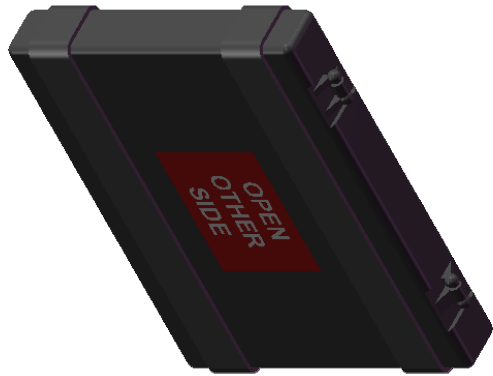

**FILLED
TOP VIEW
SINGLE**

Notes: (Unless Otherwise Specified).

1. DIMENSIONS INCHES.
2. MEASUREMENT INCLUDES RUBBER BANDS.
3. BOX SIZE SUBJECT TO CHANGE.

TopLine®

TITLE CCGA TRAY BOX CARRIER
CARTON

SCALE 1:2	SIZE A	DRAWING NO. 900001	REV A
--------------	-----------	-----------------------	----------

DO NOT SCALE DRAWING

SHEET 12 OF 12