

**UPPER GRAPHITE
TOP SIDE**

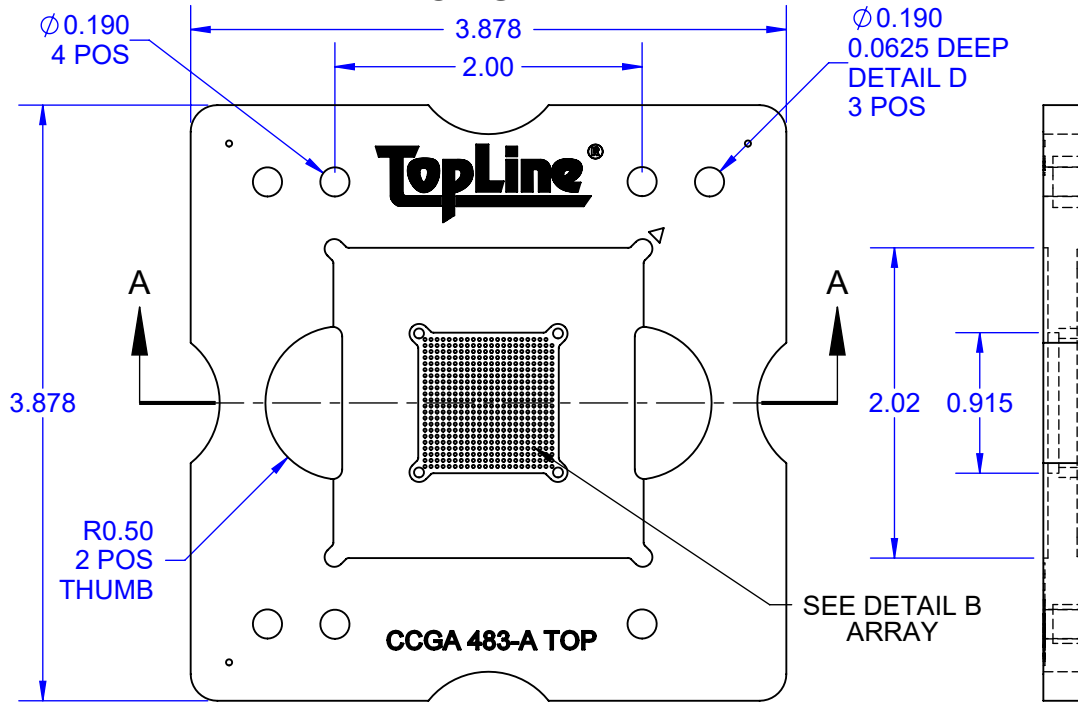

EDGE



**UPPER GRAPHITE
BOTTOM SIDE
VIEWED FROM TOP**

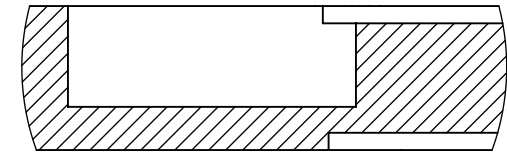
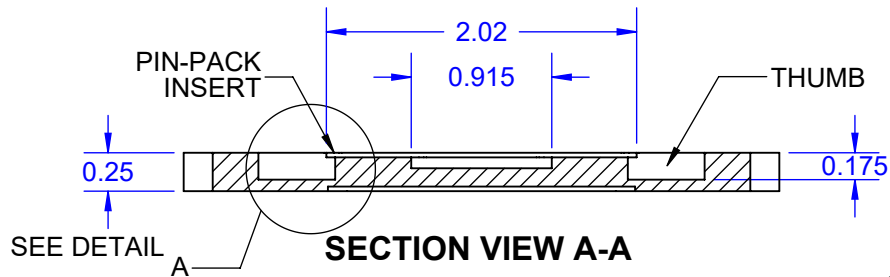
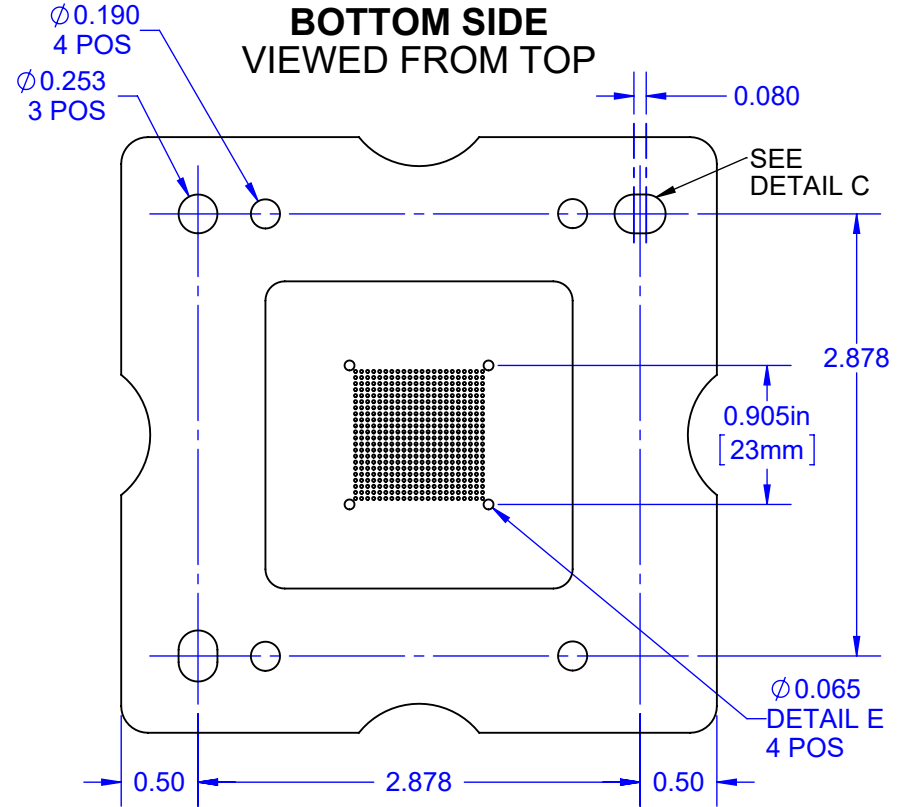

**DETAIL A
SCALE 3 : 1**

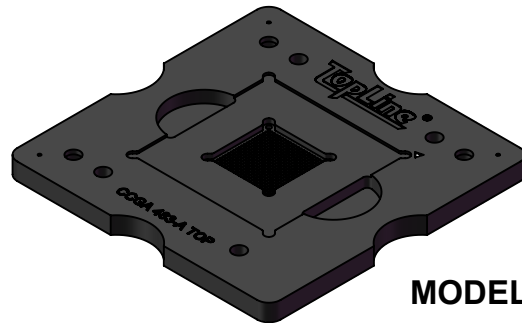

MODEL

NOTES:
1. DIMENSIONS in INCHES.

APPROVALS	DATE	TopLine®			
DRAWN T.Au	12/21/15				
ENG M. Hart	12/21/15	TITLE C7-GRAPHITE-483-A COLUMN ATTACHMENT TOOLS			
MFG		SCALE	SIZE	DRAWING NO.	REV
QA		1:1.25	A	712280	A
CUST		DO NOT SCALE DRAWING			SHEET 1 OF 9
REVISED					

VIEWED FROM BOTTOM

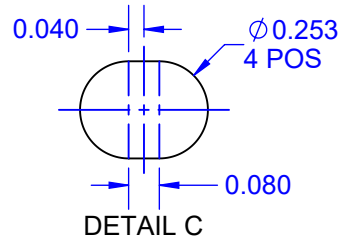

VIEWED FROM TOP

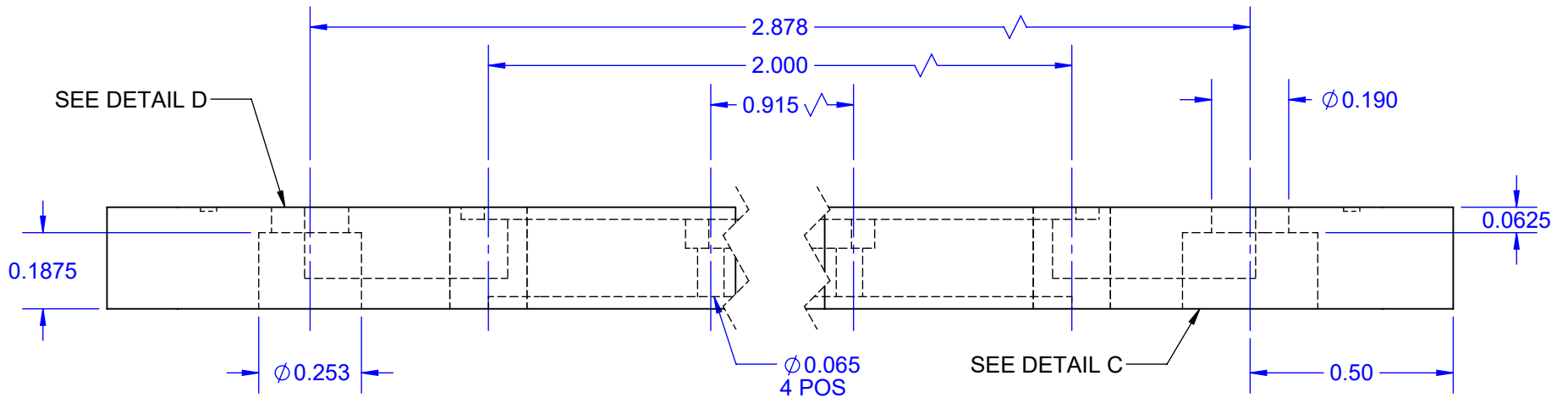
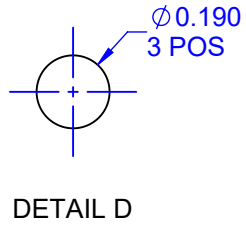

SECTION VIEW

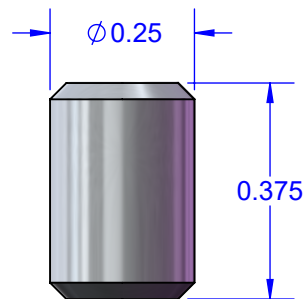

**1/4-Inch PEG
 POSITIONING**

TopLine®

TITLE C7-GRAPHITE-483-A
 COLUMN ATTACHMENT TOOLS

SCALE 2.5:1	SIZE A	DRAWING NO. 712280	REV A
----------------	-----------	-----------------------	----------

DO NOT SCALE DRAWING

SHEET 2 OF 9

**DETAIL B
ARRAY
22 x 22 MATRIX**

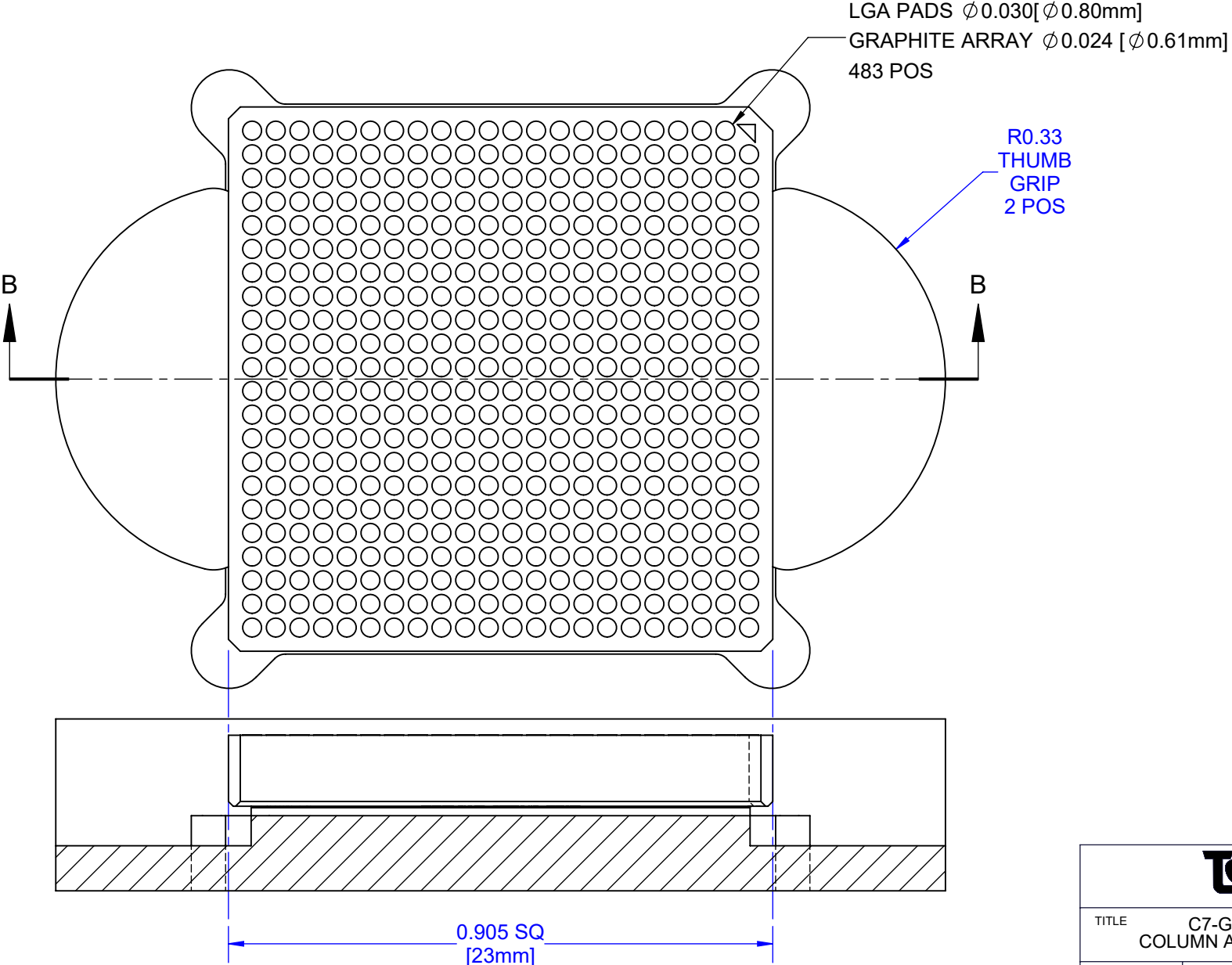

TITLE C7-GRAPHITE-483-A COLUMN ATTACHMENT TOOLS			
SCALE 4:1	SIZE A	DRAWING NO. 712280	REV A
DO NOT SCALE DRAWING		SHEET 3 OF 9	

DETAIL E 22 x 22 MATRIX

BOTTOM VIEW OF TOP GRAPHITE RIGHT READING

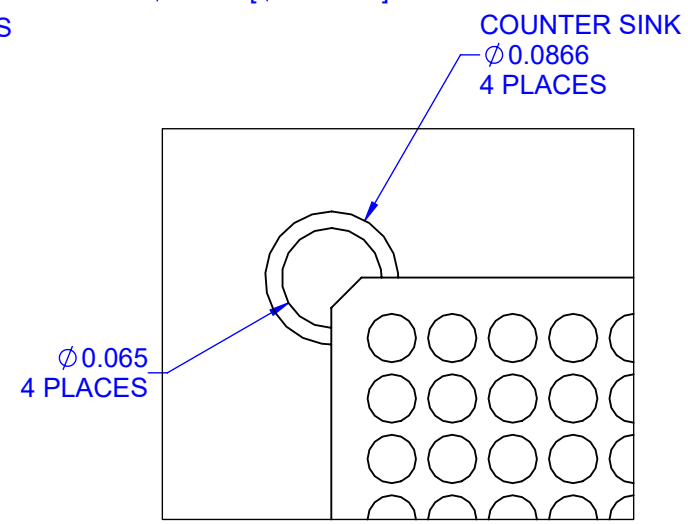
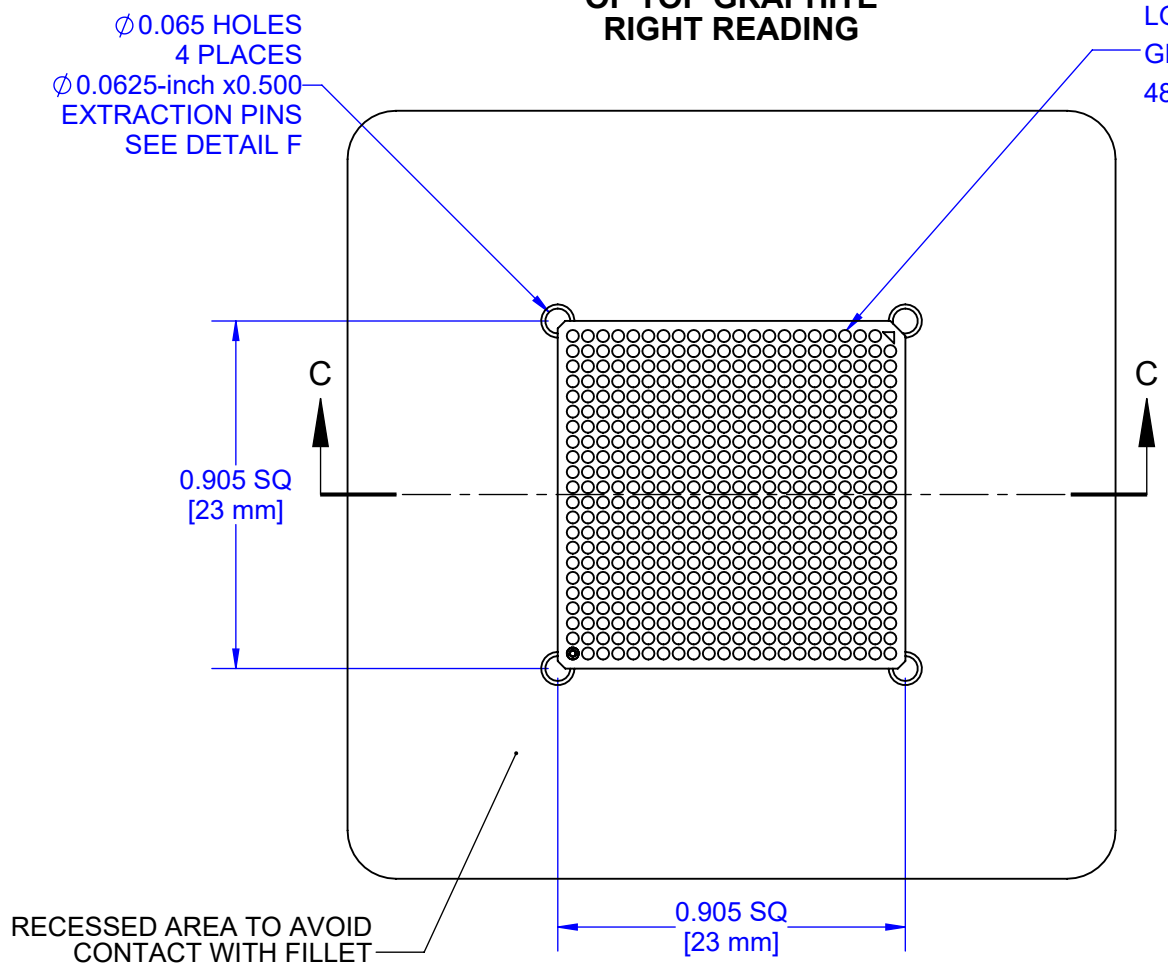

DETAIL F SIDE VIEW

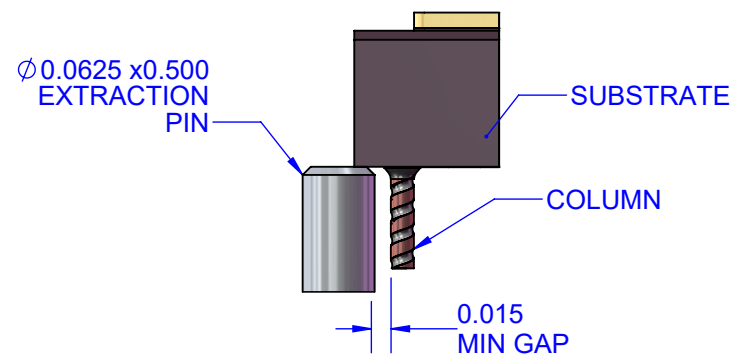

DIRECTION
EXTRACTION PEGS

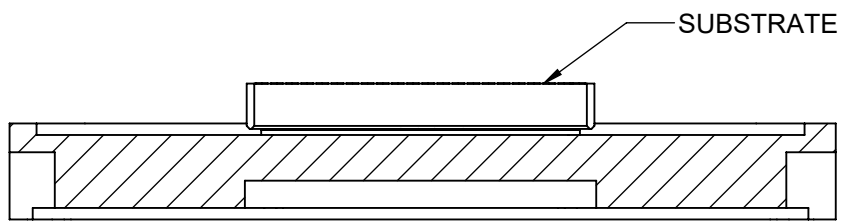

SECTION C-C
SCALE 2 : 1

TopLine®			
TITLE C7-GRAPHITE-483-A COLUMN ATTACHMENT TOOLS			
SCALE 4:1	SIZE A	DRAWING NO. 712280	REV A
DO NOT SCALE DRAWING			SHEET 4 OF 9

**BASE GRAPHITE
TOP SIDE**

**BASE GRAPHITE
BOTTOM SIDE**

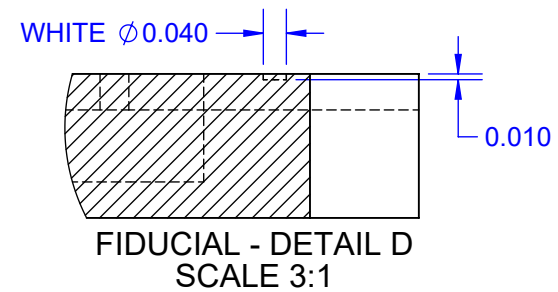
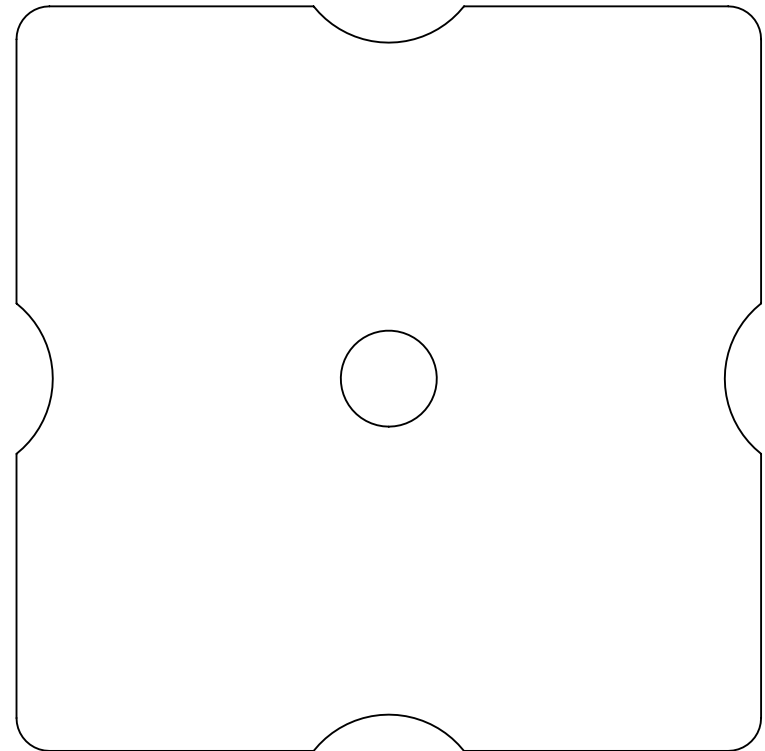
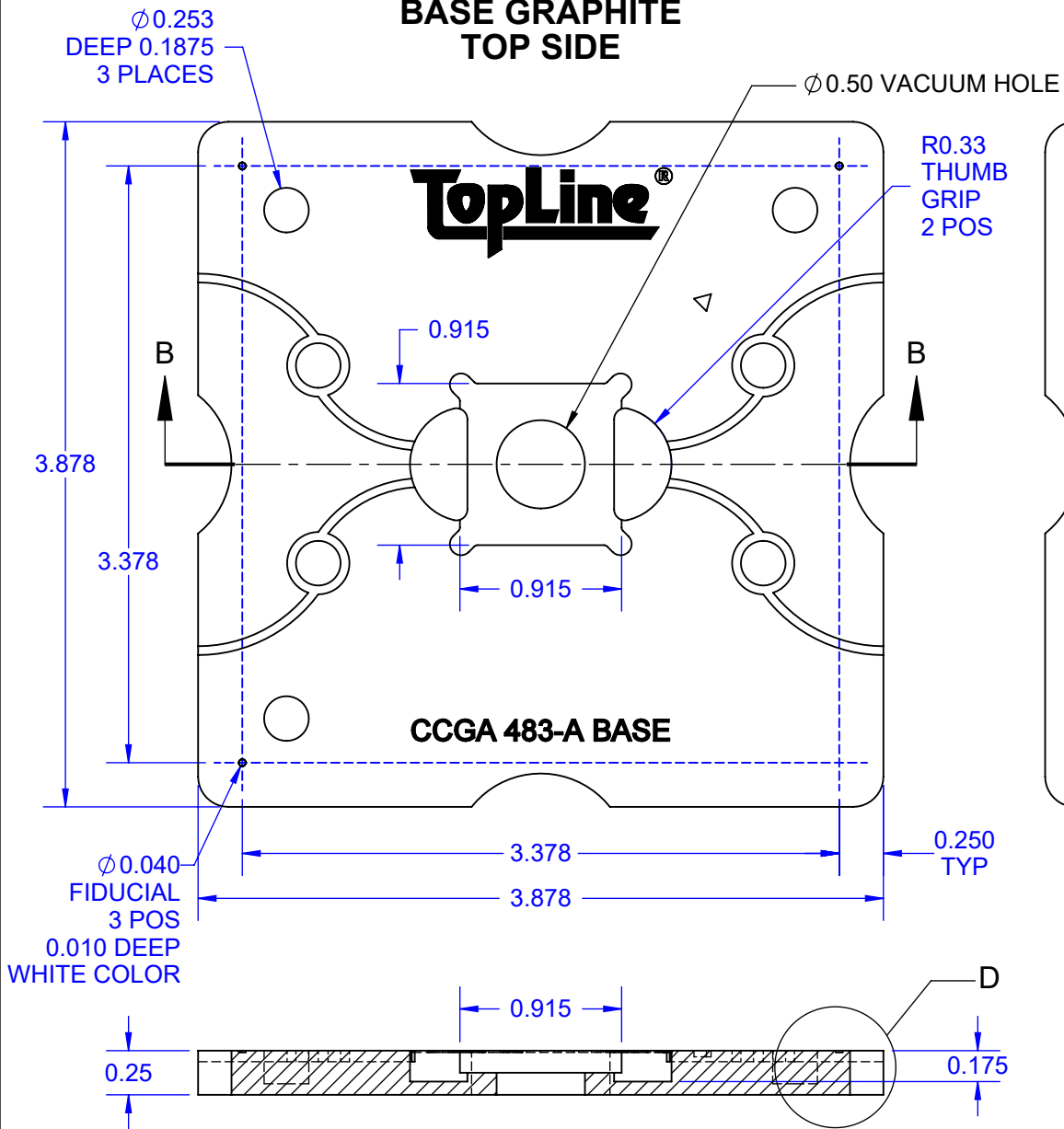

NOTES:
 1. DIMENSIONS in INCHES.

TopLine [®]			
TITLE C7-GRAPHITE-483-A COLUMN ATTACHMENT TOOLS			
SCALE 1:1	SIZE A	DRAWING NO. 712280	REV A
DO NOT SCALE DRAWING			SHEET 5 OF 9

UPPER GRAPHITE
TOP SIDE
SHOWN WITHOUT PIN-PACK™

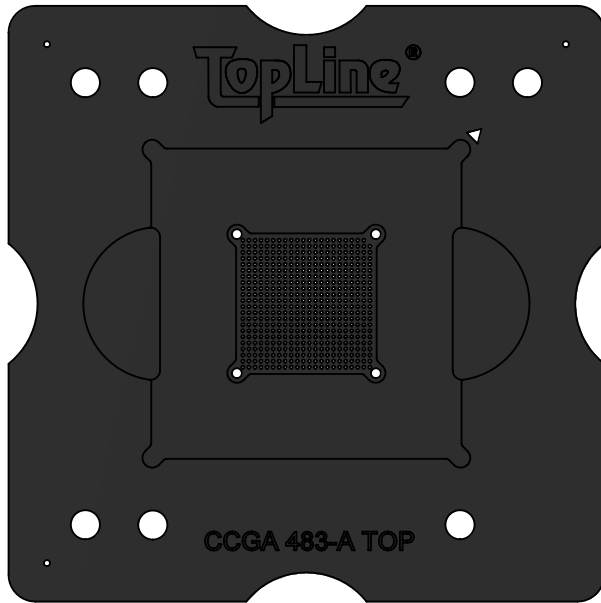

MODELS

UPPER GRAPHITE
BOTTOM VIEW
RIGHT READING

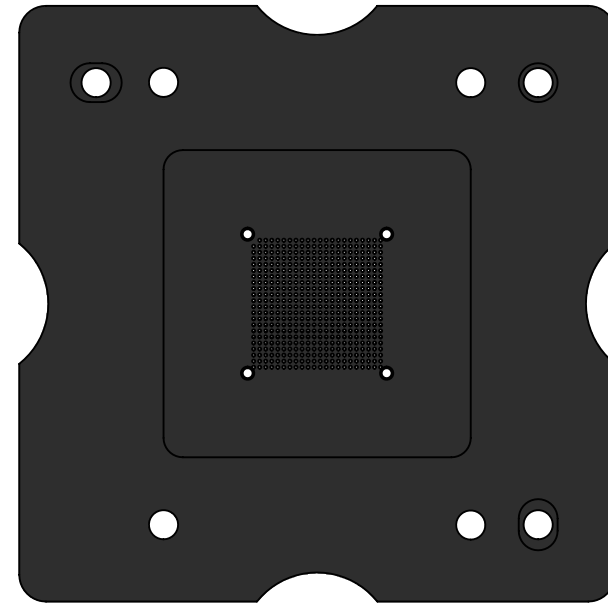

UPPER GRAPHITE
TOP SIDE
SHOWN WITH PIN-PACK™

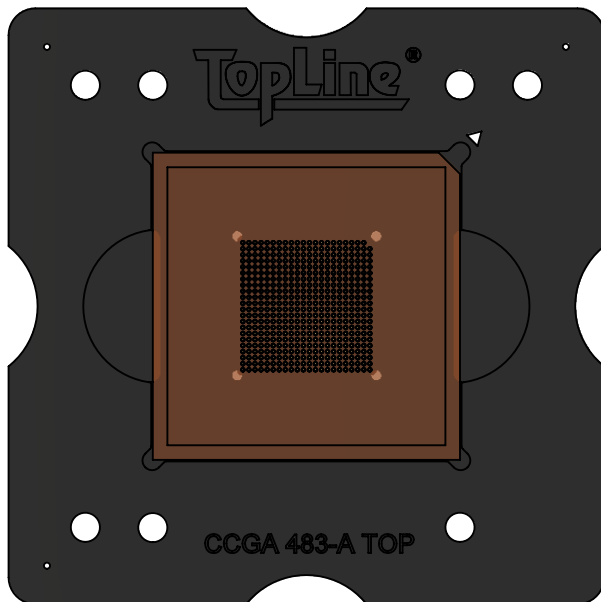

3x PEGS
0.250 x 0.375

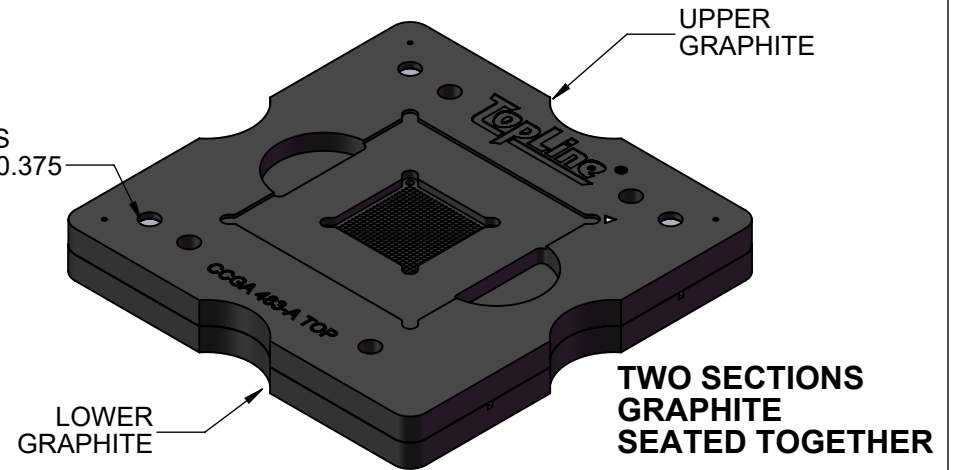

TopLine®

TITLE C7-GRAPHITE-483-A
COLUMN ATTACHMENT TOOLS

SCALE 1:1.25	SIZE A	DRAWING NO. 712280	REV A
-----------------	-----------	-----------------------	----------

DO NOT SCALE DRAWING

SHEET 6 OF 9

**BASE GRAPHITE
TOP SIDE**

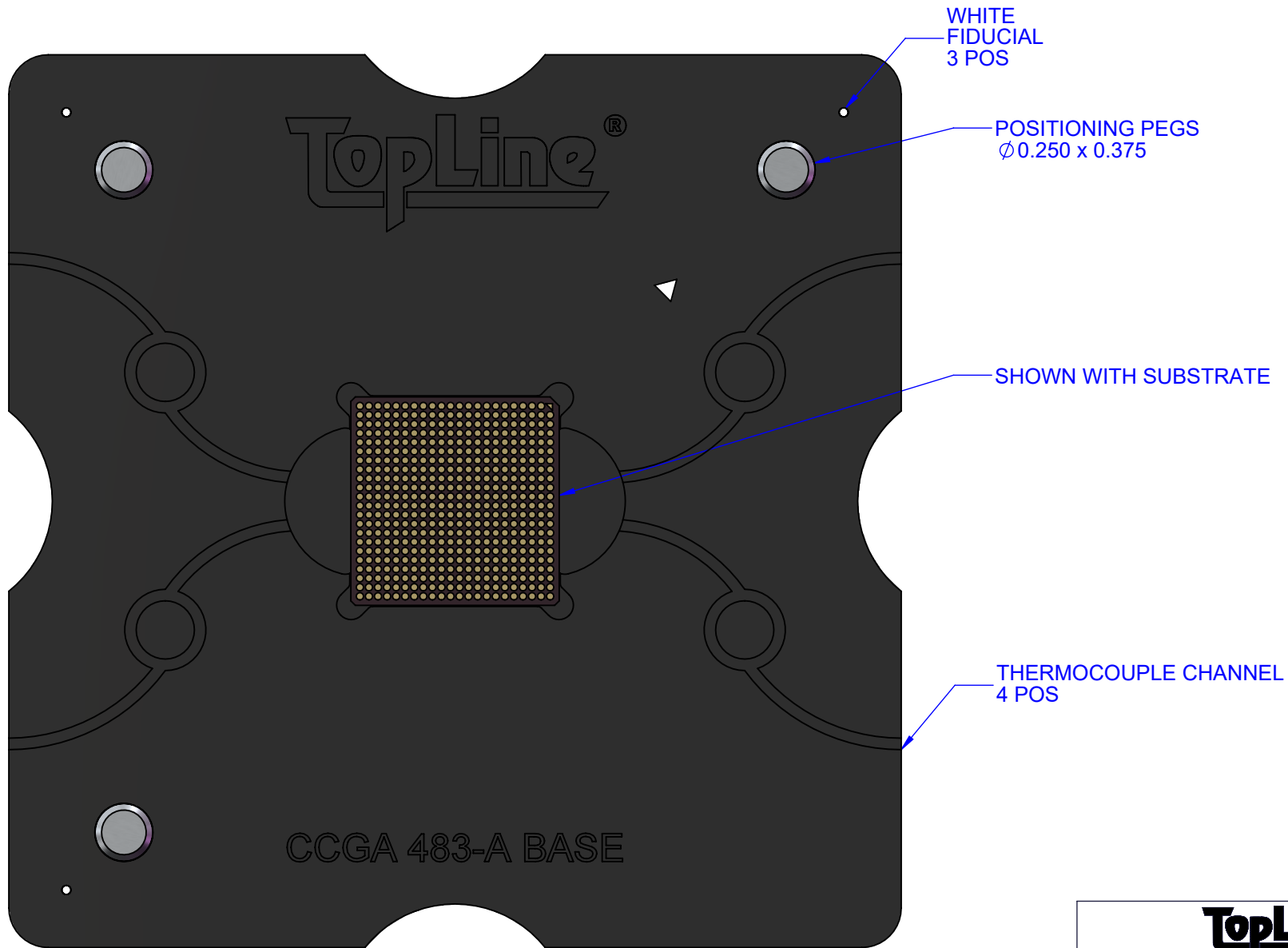

NOTE 1. APPLY SOLDER PASTE TO SUBSTRATE PADS BEFORE COVERING WITH TOP GRAPHITE.

TopLine®			
TITLE C7-GRAPHITE-483-A COLUMN ATTACHMENT TOOLS			
SCALE 1.5:1	SIZE A	DRAWING NO. 712280	REV A
DO NOT SCALE DRAWING			SHEET 7 OF 9

COLUMN ARRAY
IN HOLES

EXPLODED VIEW

PIN-PACK™
PATENT PENDING

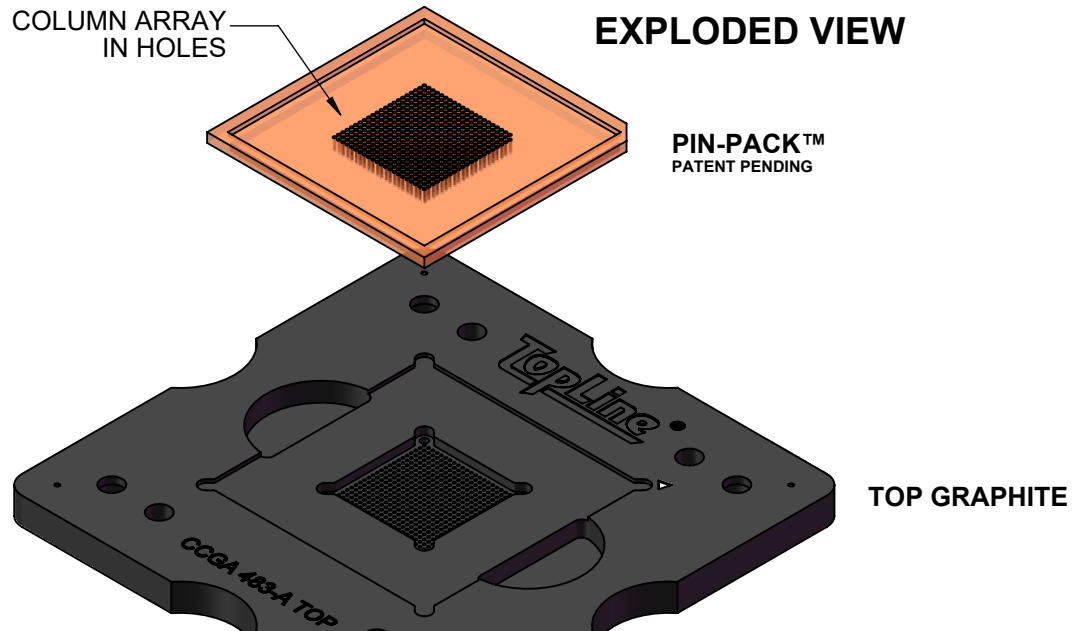

TOP GRAPHITE

DIRECTION OF FEED
↓

COLUMNS GRAVITY FEED

LGA SUBSTRATE

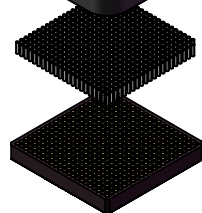

PEGS

PEGS

BASE GRAPHITE

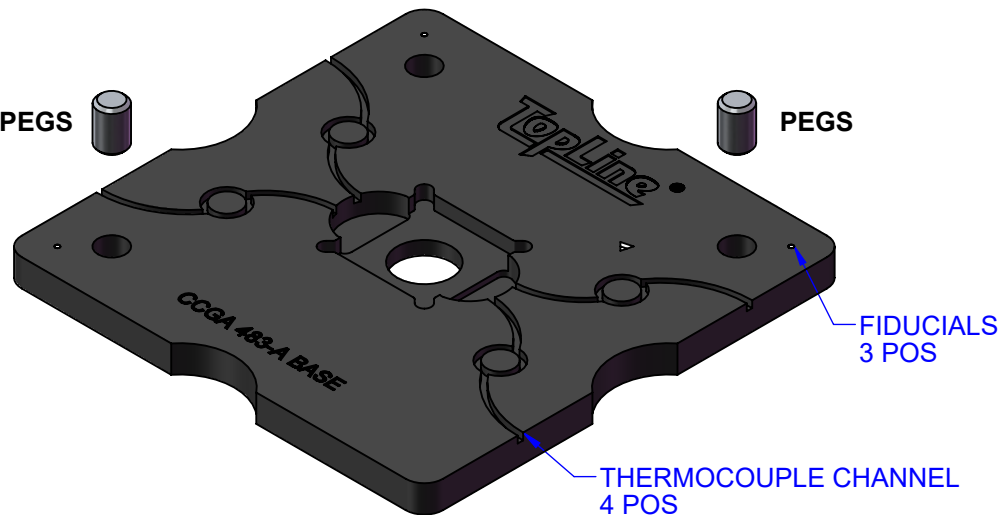

FIDUCIALS
3 POS

THERMOCOUPLE CHANNEL
4 POS

TopLine®

TITLE C7-GRAPHITE-483-A
COLUMN ATTACHMENT TOOLS

SCALE 1:1.25	SIZE A	DRAWING NO. 712280	REV A
-----------------	-----------	-----------------------	----------

DO NOT SCALE DRAWING

SHEET 8 OF 9

TOOL PART NUMBERS & ACCESSORIES

MODEL NUMBER	DESCRIPTION	LGA X/Y SIZE	LGA Z - HEIGHT	PAD MATRIX	PITCH	DWG
C7-GRAPHITE-483A	GRAPHITE SET	23mm SQ 0.905-inch	3.2mm 0.126"	22x22	1.0mm	712280
C7-BASE-483A	GRAPHITE BASE	23mm SQ 0.905-inch	3.2mm 0.126"	22x22	1.0mm	323320
C7-TOP-483A	GRAPHITE TOP	23mm SQ 0.905-inch	3.2mm 0.126"	22x22	1.0mm	512280
PEG-.25x.375	ALIGNMENT PEG	6.35 x 9.52mm 0.25 x 0.375-inch	ALL	ALL	ALL	702551
PP83C483E20x91A	Pin-Pack Pb80/Sn20 Copper	0.51 x 2.31mm 0.020 x 0.091-inch	ALL	22x22	1.0mm	831220
PP90U483E20x91A	Pin-Pack Pb90/Sn10 PLAIN	0.51 x 2.31mm 0.020 x 0.091-inch	ALL	22x22	1.0mm	901220

NOTE: FOR MICRO-COIL SPRING, USE DWG 712281 C7-GRAPHITE-483-M

TopLine®

TITLE C7-GRAPHITE-483-A
COLUMN ATTACHMENT TOOLS

SCALE NONE	SIZE A	DRAWING NO. 712280	REV A
---------------	-----------	-----------------------	----------

DO NOT SCALE DRAWING

SHEET 9 OF 9